

DONALD A DALE
P.O. Box 699,
ORLEANS, ONT., CANADA

NEWSLETTER #41

September, 1972

Dear Fellow Builders:

Summer fun is over and its time to hibernate in the basement again. I hope my readers had better summer weather than we had here in Ottawa; apparently we broke some long-standing records for lousy vacation weather.

I must apologize to those who looked for me in Oshkosh. I arrived there on Saturday night late and bedded down. On Sunday my two boys and I looked around a bit but the weather was bad and there was not much action. My youngest son took ill Sunday and I had to hurry home early Monday morning so my truncated stay was over. I met a few people and (at last!) got to shake the hand that designed the PL-'s.

I had received hardly any material for a Newsletter in August so I decided to put out a larger one in September. Well, the roof has fallen in on me, and I have a lot of stuff for this one. I hope everyone finds it to be of help. I was in the North-Eastern U.S. the other week and some of my business friends took me to a Playboy club. Now I have secretly wanted to see one of these places for a long time and this was my chance but I'm afraid I will never look at my Pazmany in the same way again! I used to think airplanes were the living end but now I'm going into the rabbit business.

David Lavender of Columbus, Ohio would like one of you hot-dogs to tell him the best way to bend up ribs. Some people have come on strong with the simple bend 'em and heat-treat 'em method while others have used a more sophisticated method. I do not recall where I read this, but one man put out an article whereby he cut the rib blanks, took them through the heat-treat process, stored them immediately in his freezer and then at his own pace took them out one at a time and formed them on a block and allowed them to harden in the room temperature environment. May I please hear from the experienced and I will publish it in the next letter.

A request was received some time ago for a good joggling method; well we have come up with one and it is included here.

Tom Phelps, 1200 Hamsted St., Fort Worth, Tex. 76115 has the following for sale.

.190"x4"x72" 2024-T3 BARE \$5.25 each plus postage-- 22 pieces on hand.

.080 x26x36 2024-0 Clad \$15.00 each " " 4 " " "

Fuel Cap 42-A-3589 \$2 plus postage

Filler Neck 39-B-4233 \$2 plus postage both in good shape, need new paint

Wanted: (same fellow)

1 piece .063 x 12 x 18 2024-0 Clad

1 piece .250 x 4 x 18 2024-T3 Bare

1 piece .375 x 4 x 36 2024-T3 Bare

2 pieces .050 x 18 x 36 steel 4130N MIL-S-18729

One new Airmaze air filter Model NO. 13203 Type P-IS by Rockwell-Standard

If anyone has a new O-290-G for sale please contact Mr. R.L. Carpenter, 11216 Hartland Rd., Fenton, Mich. 48430.

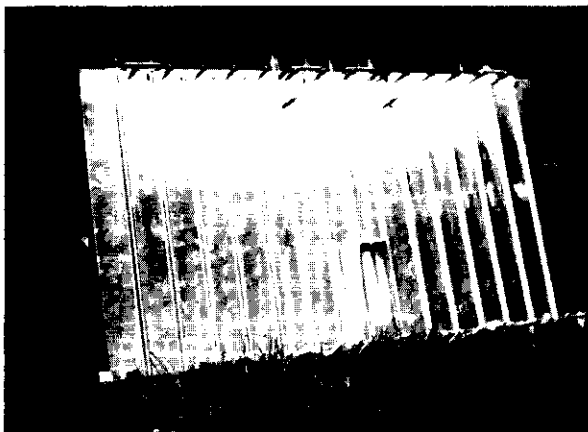
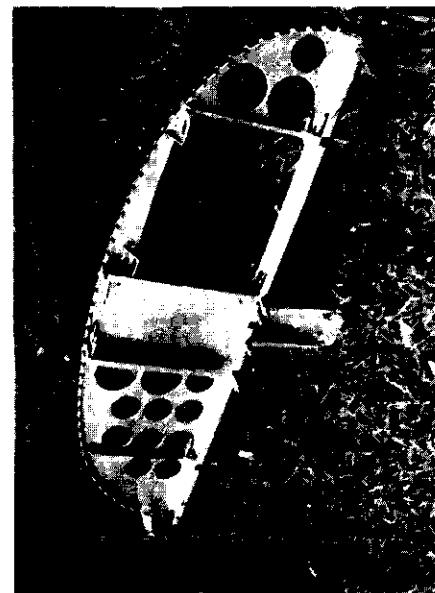
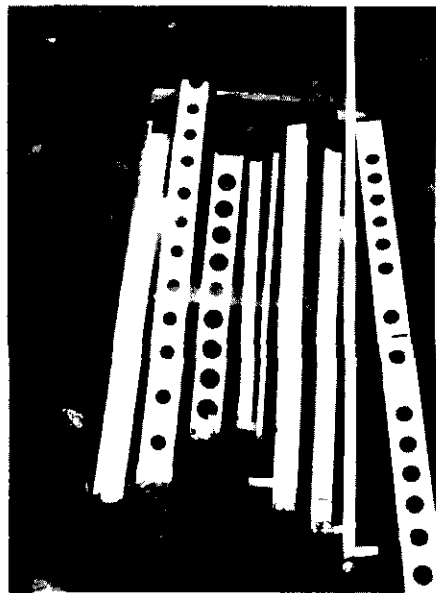
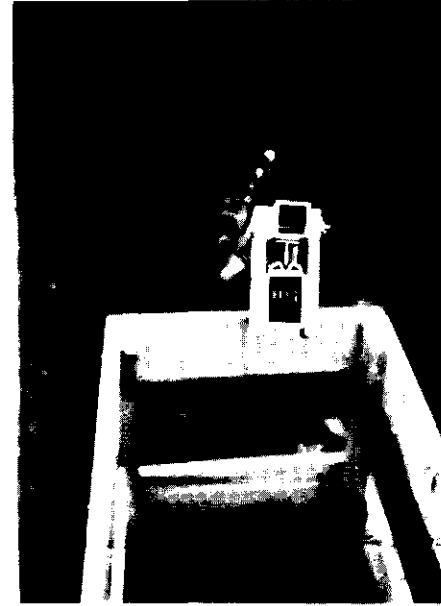
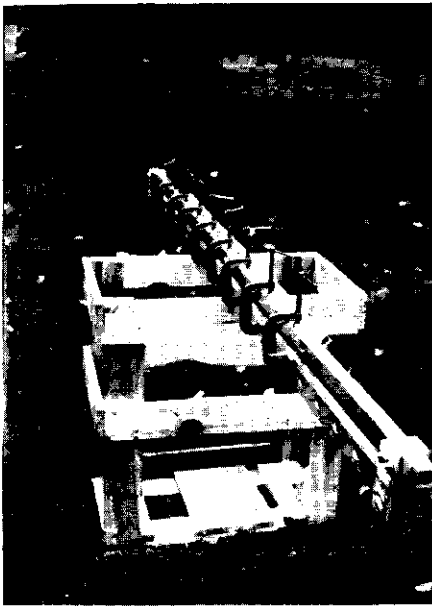

Each of these pictures is explained in the text of the Newsletter.

MATERIALS REQD:

- 1. - 3 INCH C-CLAMPS
BRINK & COITON #143-3 CR.
- 2. - 6063 ALUMINUM, LENGTH
AS DESIRED
1 1/2 x 2 x 1/8 RECTANGLE TUBE
1/2 x 1/8 FLAT STOCK - 2 PCS
1/2 x 1/2 x 1/8 ANGLE - 2 PCS
1 x 1 x 1/8 TEE
1 1/4 x 1 1/4 x 1/8 SQUARE TUBE.
- 3. - CSK SCREWS 10-24 OR
1/2" LONG 6/FT
3/4" LONG 12/FT

AIRCRAFT PRESS
BRAKE FOR HOME-
BUILDERS

-WILL BEND 2024-T3 UP TO
.040 THICK, DOWN TO 74"
INCLUDED ANGLE.

D. J. PANTON, PL2-110
EAA 59365
WINDSOR ONTARIO

SPRING BACK
ALLOWANCE - 7°
FOR 2024-T3

LOCATE ALL
SCREWS ON
4" CENTRES.

OPERATION TIPS

- 1. - OIL ON ANGLES CUTS
SCUFFING TO NIL
- 2. - .025 - 2024-T3 AND
LESS NEED CLAMPS ONLY
EVERY 2 HOLES.
- 3. - CAPACITY 0.040 2024-T3.
USE BIG OUTSIDE CLAMPS
EXTRA FOR 0.050 UP
- 4. - PLAN YOUR BEND TO
AVOID "STRESS CONCENTRATIONS"
- 5. - AS SHOWN BEND RADIUS IS
OBTAINED SOFT SHEET TO
PAD NOSE FOR GREATER RADII.

1" DIA CLAMP
ENTRANCE HOLE
EVERY 4 INCHES -
LOCATE TO CLEAR
SCREWS.

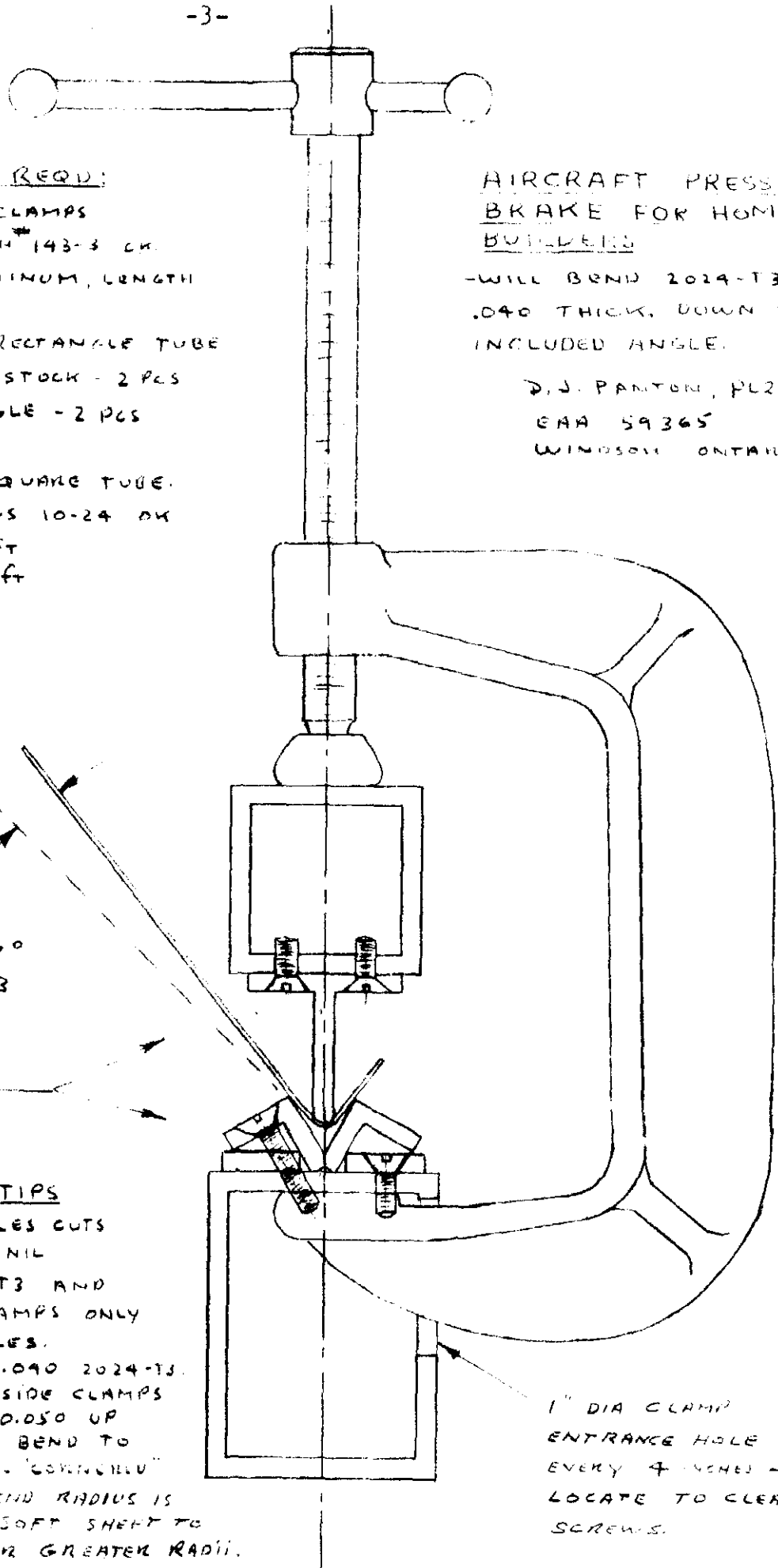

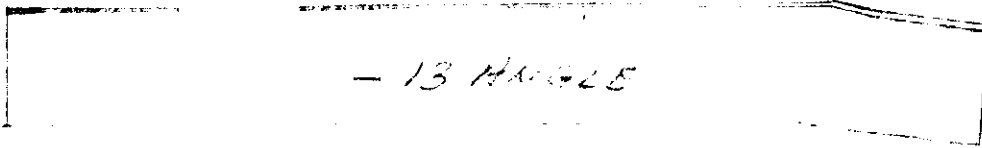

- 13 ANGLE

JOGGLING 2-10-002-13 AND -14 AS SHOWN MAIN STAR ASSEMBLY

1. MAKE CAP AND BASE OF HARDWOOD.
2. PENCIL MARK.
3. RADIUS EDGES OF BASE BLOCKS TO RECEIVE ANGLE RADIUS.
4. .10" GAP CONTINUOUS BETWEEN BASE BLOCKS SPACE WITH WASHERS.
5. PLACE ANGLES ON BASE BLOCKS AS SHOWN TAPE WITH MASKING TAPE.
6. MATE CAP TO BASE AND PRESS TOGETHER IN BENCH VISE.
7. REMOVE ANGLES FROM BLOCKS.
8. SHRINK THE DISTORTED AREA AS FOLLOWS:
 - A. PLACE A MAN'S HARD RUBBER SHOE HEEL ON A SOLID SURFACE. A BLOCK OF STAIN WOOD WILL DO.
 - B. PLACE DISTORTED AREA OF ANGLE ON RUBBER HEEL AND TAP SMOOTH WITH A SMOOTH FACE HAMMER.
9. PLACE JOGGLE FORK ON ANGLE AS SHOWN BELOW AND SQUEEZE IN BENCH VISE.

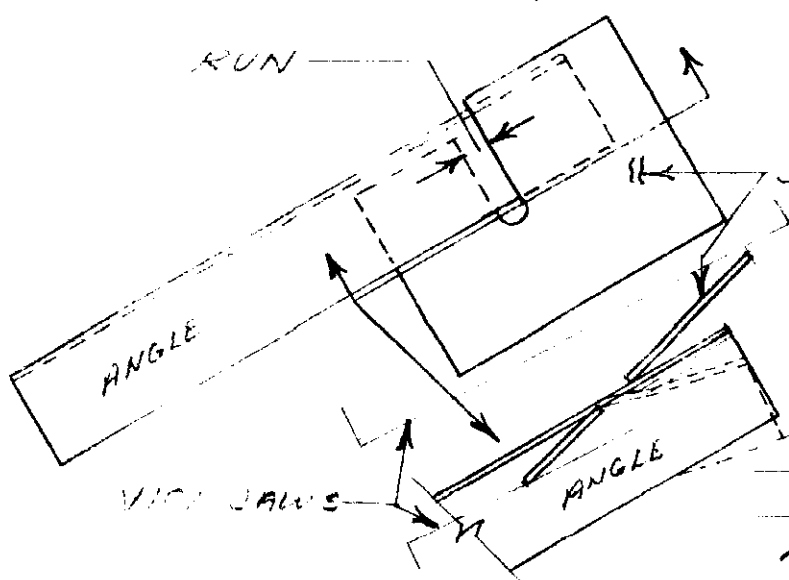
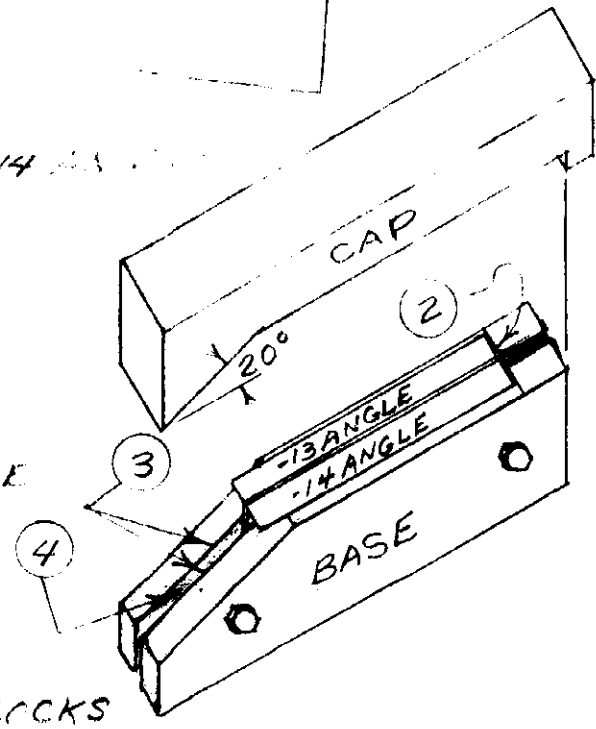

THICKNESS OF FORK DETERMINES DEPTH OF JOGGLE. WIDTH OF NOTCH DETERMINES RUN OF JOGGLE.

INDICATES NORMAL JOG.

INDICATES DOUBLE JOG. AS DESCRIBED ABOVE.

I have so much material from Dave Panton of Windsor, Ontario, Canada that I should produce a separate newsletter to publish it. Here goes.

Dave provided the enclosed brake design. The pictures represent:

- (1) Rear view of brake with aileron in it.
- (2) Front view " " " " "
- (3) End view " " " " "
- (4) End view of sample parts made on brake.
- (5) View of above parts but without end-on detail.
- (6) Instrument panel- view from rear.
- (7) Uncompleted seat back from front. Done on this brake but with extra beefy channels added to top and bottom and big "C" clamps.

Dave describes the brake design:

"I had tried to buy a brake from many sources but couldn't get less than an 8-foot version for several hundred dollars. This size would be very cumbersome and I have only limited working space. Local schools had no night courses where their shops would be open and sheet metal shops weren't much help when they saw the precision needed. After seeing a similar design in a Sport Aviation issue, I built a 6' long version which had limitations in not bending even a 90 degree bend due to spring-back.

Since only precision can be obtained from good tooling I felt a wood-angle-iron design was inadequate. To overcome the spring-back problem the vee groove must be a good bit sharper than 90 degrees. This was obtained by using a couple of angles stepped up on a pair of flat bars as shown in the diagram (page 3). I used 6063 extruded aluminum for the whole thing as it is very straight and its dimensions are accurate. Only a drill and tap are needed for assembly and a few hours work results in a low cost and well-built brake. Mine is 8' long. A bigger version could be built on the same principle but I chose all the material to utilize the beefy Brinks & Cotton #143-3 clamp which sells locally for only \$1.69 each. Since they are not integral with the brake they can be used elsewhere as required. I have been able to bend up to .040 2024-T3 with the design shown. .050 can be done with bigger clamps between the 3" centers.

At this writing (Aug 19) I have used my brake to bend all the parts needed for my PL-2 #110 which is progressing very well a bit at a time."

Dave also has the following for people living in Canada and particularly in the Detroit-Windsor area.

Copper and Brass Sales Inc.,
6555 E. Davison,
Detroit (313) 365-7700

These people allow customers wearing hard hats (which they provide) to wander through their bins as in a supermarket. I got Teflon rod, Nylon plate, Formica, 2024-T3 round bars, slabs and pieces of odd sized sheet at reasonable prices but best of all in minimum sizes. Minimum order \$5.00 with personal shopping only for small pieces. These people do not have a very comprehensive stock of sheet so the next address is used.

Meier Bronze & Brass,
1471 East 9 Mile,
Hazel Park, Mich (313) 396-1900

Meier supplied on order of 179 lb. mixed sheet 0.016 2024-T3 and 0, .020, .025, .032 etc with some cut sheets for \$223 including \$20. worth of cutting charges. Meier do not have any bins for personal shopping

but they make up for it by having an excellent stock of sheet sizes.

Advice to Canadian importers:

Canadians bringing material from the U.S. might be interested in Canadian Customs Tariff Item numbers which can save a lot of money. Bring aluminum in under T.I. #35302-1 at 2¢ per pound plus 12% FST. The duty officer will always argue and want 17% plus 12% FST but the 2¢ per pound is in his book and is correct.

- T.I. #39705-1 Steel tubing 5% duty plus 12% Federal Sales Tax
- T.I. #44051-1 Aircraft parts not made in Canada 0% duty & 12% FST
- T.I. #44052-1 Aircraft parts of a kind made in Canada 7% Duty plus 12% FST
- T.I. #69605-1 Aviation training aids not for resale and not made in Canada to be used in a school of aviation (e.g. flying training) 0% Duty & 0% FST

Well Dave Panton you have certainly earned your HERO badge for 1972 and I thank you very much for the above information.

We owe a thank you to W.C. Gramatzky for the following regarding the leaky oleo situation. Paz has looked this over and gives it the OK.

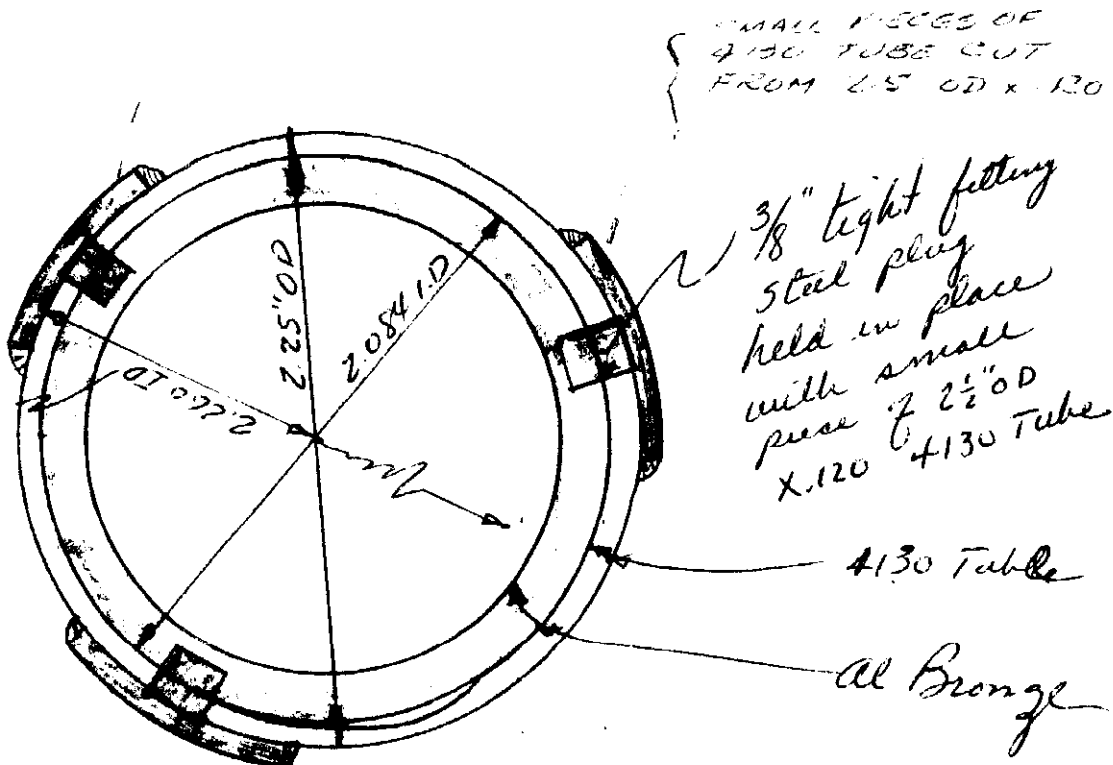

Ken Arnold of Kansas City says he has temporarily stopped making mufflers and stacks until he has his PL-2 flying. He has about 15 sets partially made and plans to fly his PL-2 this winter and will probably resume production. Contact him with questions.

I thank everyone for the response to paying your subscriptions. I have paid back the loan to my wife and she has charged me no interest but I had to agree to give her back the TV room and move my Flugewerk out to the garage. It is surprising how large that room looks without a fuselage in it.

Did any of you happy critters see the PL-4 in Oshkosh-- I think Paz has a winner here!

Best regards to all.

Don Dale