

Pazmany Newsletter
Number 66

September 1981
Rate \$4.00/year

AIRCRAFT DESIGNER
Ladislao Pazmany
P.O. Box 80051
San Diego, Cal.



PAZMANY PL-2

EDITOR PL-2
Dave Panton - Lib Panton
3565 Askin Ave.
Windsor, Ontario, Canada
N9E 3KI

EDITORIAL COMMENT: Our long mail strike is over and the flow of correspondence is beginning to move again so another newsletter is in order. All the photos, comments, diagrams sent by subscribers are very helpful and of course are vital to a useful newsletter. Many thanks for all of them --- their value will be seen in the following pages.

Our own PL-2 Serial # IIO C-GQUK is being flown steadily and now has 485 hours since its first flight in November 1978. We have just returned from our third round trip to British Columbia and are especially pleased with the improvement in performance via a nice new set of wheel pants designed by Paz. Making the styrofoam ma. moulds and laying up the glass fibre was easy. Finishing them was quite another matter. Many hours went into filling, sanding, microballooning, priming, etc. Doug Marsland at St. Clair Aviation did his usual fine job of painting for me and the final product looks superb. Credit again to Paz as not only do they look good, but also they make for genuine improvement in cruising speed, fuel consumption and range.

I generally fly by RPM, a little under 2400 with a I35 HP Lyc 0290-D2 running a McCauley AGM 7063 prop. The fuel consumption averages 4.8 imp.gal/hr and T.A.S. will be about I32-I33 MPH. At these conditions, the boost in speed is about 10 MPH and the fuel consumption cut from 5.3 GPH. Compare the following over two similar 5500 mile trips:

	<u>Gross</u>	<u>Fuel</u>	<u>Avg. Block Speed</u>
1) No Fairings	I575 lbs.	5.3 GPH	I13 MPH
2) With Fairings	I590 lbs.	4.8 GPH	I28 MPH (partly due to better winds)

The resulting greater endurance and range are a real plus as one can fly over fuel stops and save a lot of time.

The aircraft is being carefully maintained and the following problems have been noted for others to watch: The forward end of the mufflers have regularly developed cracks in spite of bell joints installed to help avoid such difficulty. The oil cooler mounting assembly has also developed cracks (I designed and built it forward of #2 cylinder with airflow 90 degrees downwards). One of the main gear scissor legs developed a crack which I was very fortunate to note before failure. I made them from the 4I30 steel optional construction and was never entirely happy with them as a lot of welding is needed and I felt there could be some loss of strength as a result. If anyone has a spare set of the 2024-T3 aluminum scissor links, I am in the market.

I replaced the wire type push-pull cable control to the cowl flap with a throttle control and solved the problem of engine cooling at full throttle. The rod ended throttle control holds the cowl flap wide open

against the airstream pressure loads. The wire type tended to blow partly shut (as best I can theorize). Having good control over the cowl flap is important as it affects aircraft trim and speed via cooling airflow losses.

Quite by coincidence we happened to travel east from B.C. with an early model Piper Arrow CF-UKE. To my delight we found our block speeds were almost identical over a period of two days and some 1800 miles of travel. Considering their constant speed prop and retractable gear, I think our little PL-2 did very well and burned a lot less fuel to boot.

Keep those projects going! The PL-2 is one very fine aircraft as it has such a nice combination of all the good things that go into a firstclass flying machine.

BOB BRADLEY, 44 Beach St., Marblehead, Mass. 01945, writes he has completed his exhaust system and has the whole area forward of the firewall ready for covering. He has passed his biennial, a perfect physical at 69 and is hoping to fly his PL-1 this summer. We wish him well on that especially exciting first flight.

PAZ SEZ: He has new drawings for alternate spar caps due to high prices and 2 year delivery from Alcoa for extrusions. See the attached copy of his letter and Engineering Change Notice #5 detailing some odds and ends of details noticed by a builder in Kitchener, Ontario.

JIM NEISWONGER, McFarland Aircraft Co., P.O. Box 1353, Spring Valley, Cal., supplies PL-2 components and is a PL-2 builder himself. Jim says he is supplying parts for PL-2s being built world wide and there are many under construction as he has had a good year. He has enclosed a sketch for a "joggle plate" used to do those impossible looking joggles so important to building a PL-2. It is duplicated here:

MAKE 2024 T3 PLATES
FOR EACH MATL THICKNESS
USED IN PL-2

0.025	0.063	0.190
0.032	0.080	
0.040	0.166	
0.050		

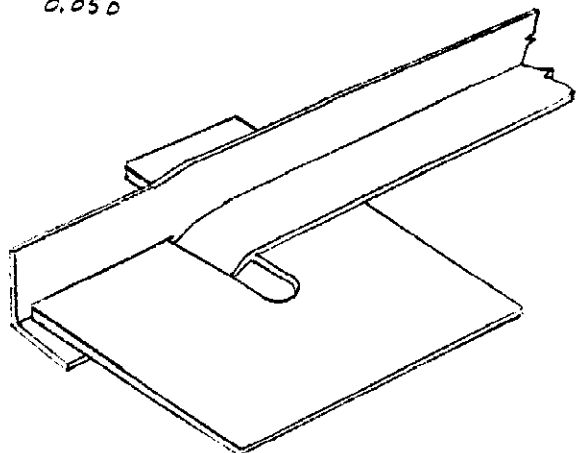

SQUEEZE IN LARGE
BENCH VISE

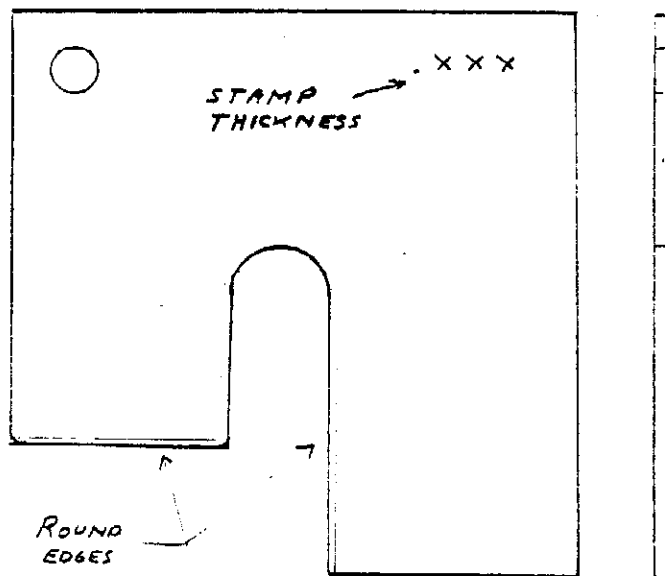

VARY THIS WIDTH
TO SUIT JOGGLE
THICKNESS

CASIMIR POROWSKI, 725 Maple Ridge Road, Milford, Ohio 45150 (Tel: 513 - 831-5032 Noon - 10.00pm) writes he has a package of PL-2 parts and material for sale including all aluminum, complete gear assembled, overhauled LYC 0290G2, weld fixtures and much more. He offers a package at \$4500. Spars, however, are missing. Call him for details and get ahead on your own project.

DEWEY GREENE, R.R.#3, Box 22, Geneseo, Illinois 61254, is slugging away at a PL-I and is making slow but steady progress, having recently installed a dual braking system and found it a plumbing nightmare as was the canopy construction. He plans to install a LYC 0-320 engine, complete the cowling, plumbing and vertical fin installation and then remove it from his mase-ment. All the best Dewey! They are indeed slow incubating birds but well worth the final hatching!

GLEN WHEELER, 119 N. Washington, Enid, Oklahoma, has moved PL-2 #86 to the air-frame shop at their local vocational technical school where the old veter-an instructor will see that it gets only the first class work it deserves. The student labour will certainly see how a well designed flying machine is in fact designed and built.

GRAHAM MANTEL, 6 Aranui St., Wellington 3, New Zealand, has put his PL-2 on a hold while he expands his Microwave Oven business over the next few months

FRANK CIOCHETTO, 79 Coronation Rd. Papatoetoe, Auckland, New Zealand, sent a long interesting letter on how to convert a LYC 0-235-C2A engine to run a constant speed propellor. He will use a Hartzell Model HC 82XL-6F prop fitted with Model 7636D-4 blades controlled by a Woodward Model 210080 (P) governor. The pitch range would run from 34" to 108" and the advantages are obvious. There are no major problems and the economy of running such a power-plant would be significant without the sacrifice of takeoff per-formance associated with a small engine and fixed pitch prop. Write to Frank for details of the conversion or to your editor for a photo-copy of Frank's letter.

AUSBY E. ALESHIRE, 1998 Mayflower Drive, Woodbridge, Virginia, 22192, has a few extra parts he would like to put up for sale. He has a complete set of aileron and flap ribs, outboard flap spars and a fibreglass tip tank kit. No prices were listed so contact Ausby directly for more details.

WILLOUGHBY GULACHSON, Site 20, Comp 28, R.R.#1, Winfield, B.C., and I had a chance to get together at Vernon's airport in B.C. while Lib and I were vacationing in late June. His progress is steady and his workmanship is certainly well done. He is planning a camper trip into the U.S. to pick up numerous parts and supplies as he found shipping costs sometimes exceed the value of the goods. We hope to fly to B.C. again next summer and will call again to see Will's progress.

MILDRED ARNOLD, 9415 Madison, Kansas City, Missouri 64114, has many components of a wet wing that she and her husband Ken were building for the very well known PL-2 N72KA. Ken's passing left the project unfinished and she has put the parts up for sale. She would prefer to sell the project as a whole.

The following are listed: landing gear and fairings (Main) \$375.00; Cleveland wheels and brakes \$325.00; control stick assembly \$130.00; wing spar and ribs (to include 2 finished ailerons, centre wing panel parts, sheets 1 & 2, and all small parts) \$1250.00; one set each of PL-1 and PL-2 blueprints. I hope no one else has missed receiving newsletters, for some reason Mildred's have not made it through the mails.

TOMMY PHELPS, 1200 Hamsted, Fort Worth, Texas. A shelf project at the moment as Tom's PL-2 awaits completion of home renovations and construction of a new workshop. Once finished, the PL-2 will likely have a speedier trip down the assembly line in the new shop.

WALTER BUTLER, R.R.#1, Box 80, Shoals, Indiana 47851, has started assembly of the wing centre spar section and is doing so without a jig, and wonders if any others have had success omitting jig construction. I haven't heard of this but saw a deHaviland Beaver fuselage tailcone being rebuilt without a jig. The fellows were doing the job without apparent difficulty and said doing it without a jig "was good enough for a factory airplane".

AL BARTEL, 1153 E I68th St., Cleveland, Ohio 44110, (Tel: 1-216-486-9265) has his fuselage nearly complete and is looking for a canopy frame or the use of a canopy frame mould. He offers a stabilizer in trade or will pay for moulding services from someone's finished mould. Also he asks if anyone has built a metal canopy frame. Perhaps a PL-1 builder can provide advice on such frames. My own experience is with a Rattray frame which required extensive rework to be utilized. Also, I have seen a frame from Homebuilders Associates used by ROSS WHITNEY in London, Ontario. This frame was a good one which Ross fit quite easily to his aircraft. Can anyone assist Al??

HENK VAN DEN HEUVEL, 110 Cann St., Bass Hill 2197, Australia, built and flies VH-ETC, Australia's first PL-2 featured in Newsletter #65. Henk now has 120 hours on his "Pazy" and is very pleased and proud of his aircraft. He is looking for a set of Pazmany designed wheel pants and would like to make a deal with anyone who has a set of moulds. Unfortunately, my styrofoam make moulds had to be destroyed to free the shells. Ross Whitney is building a set of wheel pant moulds but I don't know if he would make a second set of pants from them. Recently, Ross and I flew along side by side in our two aircraft for the first time. We have identical LYC 0290-D2 engines but slightly different props. To hold even, Ross had about 175 RPM and 3" more manifold pressure without wheel pants installed. Needless to say, I was pleased with having gone to the trouble of making a set.

Having built VH-ETC 99% by himself, I'm sure Henk will easily manage a set of pants over an easy month or two of winter evenings using the methods briefly described in the last newsletter. If anyone would like a copy, Henk has sent me a newsletter copy of the SAAA NSW Division Newsletter telling of some of his many trials, tribulations and triumphs in completing his PL-2.

RUTH & JULIEN HOBBS, P.O. Box 513, Durbanville 7550 C-P South Africa, have been moving from place to place, restoring an Aeronca and gathering PL-2 bits and pieces together for 8 years and now have them all under one roof. They expect to make good progress now that they have it "all together" so to speak.

WALTER GAMBLE, Albany RR PEI, Canada COB IAO, is in the midst of a series of financial transactions involving a change of business, leaving him with a

shortage of cash to carry on his project. He has for sale from Paz: spar caps, all extrusions, plans, and Newsletters #45 - #65. HAROLD PIOS PL-2 in Romona, Cal., inspired him to want one very badly. Walter reasons if he can't build one, he will try to buy one someday when his newest business is better established.

PETER KARMOUCHE, 9 Cranfield Ave., San Carlos Cal. 94070, has a new address and a much bigger home with all sorts of room to finish his PL-2. Pete is not sitting on the ground as he is flying a Bellanca Viking on trips throughout the southwestern U.S. I am flying a set of Peter Karmouche - built fuel tanks, so we have a common bond. Yes Peter, the newly resealed and repainted tanks are still developing little blisters at the rivet areas!! Why these tanks are giving trouble is a mystery as Ross Whitney and Frank Kreuzer have had no problems with their own tanks. Peter has a duplicate set for his airplane so may suffer the same problems in due course. As a result of purchasing Peter's extra tanks, I have an extra set of shells and components to build a pair of tanks. Drop me a line for details as I would like to move them out of my storage space.

ANNE & JACK McCOMBS 656 Grand Street, Oshkosh, Wisconsin 54901, are flying a PL-2, and write to indicate their last newsletter was not received. All have been sent and only 2 returned due to address changes so I don't know what happened to those that didn't make it. Have you people visited Castlegar, British Columbia? We have been told that a PL-2 from "the Chicago area" visited there last year and it looked very much like ours. Flying U.S. homebuilts into Canada is apparently no problem, but I shouldn't be quoted on that comment.

JOHN & MARY KAY URBANIK, RD#1 3451 Stone Quarry Road, Fredonia, N.Y. 14063, have a PL-2 project all carefully stashed away in storage while they finish their new home. John expects to finish his new shop this fall and get back into production soon.

(P.S.: Lib, my Newsletter typist and PL-2 travelling enthusiast, has been "grounded" on both fronts due to major knee surgery in July. While she resumed typing - hence the delay in production of this newsletter - she will not be able to climb into our PL-2 'til next year.)

FLASH-Alfred E. Bouffard P.O. box 802 Maple Lane, Mattituck N.Y. 11952 Another PL-2 flies! Fred's very fine looking PL-2 shown here has just been flown by him after FAA checkout. Fred did the first flight himself following an update of his aviating skills in a Piper Tomahawk. Naturally he had no problems and said it was a great experience. N5587B is powered by a Lycoming O-235 and is shown here at its home field before the first flight.

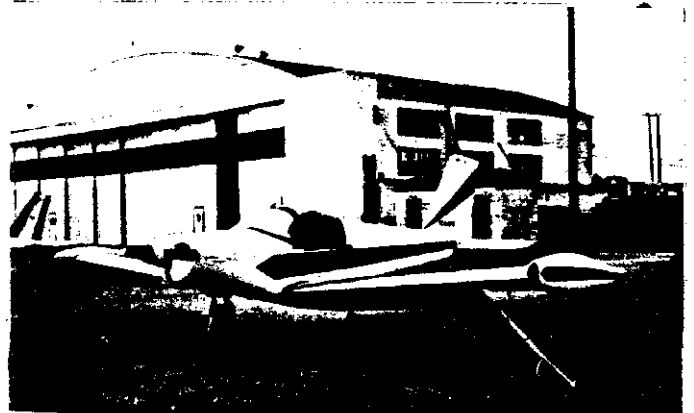

PAZMANY AIRCRAFT CORPORATION
AERONAUTICAL ENGINEERING
BOX 30351 • SAN DIEGO, CALIFORNIA 92133

Paz has passed this letter and change #5 along (following page) to be included with the newsletter so as you see it has been integrated per request.

Dave Panton

Dear PL-2 Builder:

Recently I sold the last set of spar cap extrusions which I had in stock. The price was \$800/set. Then I ordered 10 new sets from ALCOA. They quoted me a price which would raise my selling price (after I paid for the machining and crates) over \$1000/set. But, they also indicated that delivery is two years away and that final price will be set at the time of delivery. These conditions were unacceptable.

I designed a new spar which features caps built-up of sheet metal straps. Basically, a number of 2.00 in x .080 in straps of different length. The maximum thickness at the wing root have 9 straps for the upper cap and 6 straps for the lower cap. Both caps have only one strap for the outboard 50 in. The straps are bonded with Epoxy adhesive and also riveted. A tentative price for the kit of already sheared straps was quoted by Aircraft Spruce and Speciality at about \$400, less than 1/2 of what the extrusions may cost; but most important, delivery is immediate. Certainly there will be more work for the builder.

I created two new drawings: 2-10-014 Spar Assembly and 2-10-015 Build-Up Spar Caps. I also had to modify the following drawings: 2-10-001 Wing Assembly; 2-10-005 Basic Rib; 2-10-006 Root Rib; 2-10-007 Landing Gear Rib; 2-10-011 (SHT 1 & 2) Center Panel; 2-10-012 Wing Box Details; 2-50-001 Aileron Control; 2-60-001 Main Gear Assembly and 2-60-003 Landing Gear Details. The changes reflect the slightly different spar caps. Total 12 drawings. I prepared sets of prints consisting of the new drawings and partial reproductions of the modified drawings.

The cost of these new prints is \$50.00 including postage (4th Class) within the USA and Canada. Ad \$5.00 for Air Mail postage for other countries. You may want to consider ordering these drawings.

If you want the material kit of pre-cut straps, please order it directly from Aircraft Spruce and Speciality Co., P.O. Box 424, Fullerton, CA 92632.

L. Pazmany
L. Pazmany

PREPARED	NAME L. Pazmany	5-10-80	PAZMANY AIRCRAFT CORPORATION — SAN DIEGO — CALIFORNIA —	MODEL NO.	PL-2
CHECKED			ENGINEERING CHANGE NOTICE # 5	REPORT NO.	
APPROVED				PAGE NO.	

DWG 2-30-005 - TO THE RIGHT OF SEC A-A, DELETE: " PICK UP INSIDE STRAP CHANGE BJ-4 RIVETS TO BB-4 RIVETS THROUGH FLANGE OF-9 AND ANGLE -27. ON TOP OF TITLE BLOCK, CHANGE BJ-4 RIVETS TO BB-4

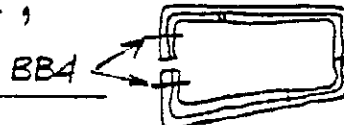

DWG 2-50-003 - -39 PLUNGER - CHANGE NOTE FOR HEAT TREATMENT TO: HEAT TREAT TO 140,000 PSI

DWG 2-30-001 - SOME OF THE SKIN SIZES IN THE B/M ARE TOO SMALL FOR EASY FITTING. INCREASE STOCK SIZES AS FOLLOWS:

-109 & -110 - 23.0 x 70.0 ; -111 - 15.0 x 50
 -115 - 16.0 x 62.0 ; -189 - 17.5 x 101.0

DWG-2-70-003 - AD 12 x AN365-832 NUT TO B/M

DWG - 2-40-004 - SECT. A-A - CHANGE HOLE TO .2500^{±.0020}/_{.0000} ON -51

DWG - 2-80-001 - BATTERY DRAIN IN BOTTOM SKIN. GROMMET SHOULD BE AN 931-6-10 - ALSO CHANGE IN B/M.

DWG-2-30-004 - THE 3/8 x .025 NEOPRENE TUBE SEAL IS TOO STIFF, USE 3/8" DIA (STICKY-BACK) HOUSEHOLD FOAM WEATHER SEAL (FOR DOORS)

DWG-2-40-010 - TWO ELBOWS CONNECTING TO ELECTRIC FUEL PUMP SHOULD BE MS 20822-6-2D INSTEAD OF MS 20822-6D. ELBOW CONNECTING TO THE BOTTOM PORT OF THE FOUR WAY VALVE SHOULD BE MS 20822-6D.

DWG 2-10-011 - SHT1 - VIEW D-D

MODIFY -45 & -46 TO CLEAR THE FUEL PUMP BOX AS SHOWN - MOVE TWO NUTPLATES OUTBOARD

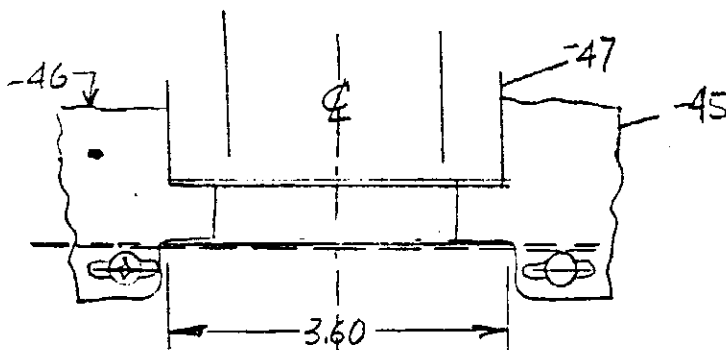

NOTE: THESE MISTAKES WERE REPORTED BY JACK LOUGH (PL-2 #15) FROM KITCHENER, ONTARIO, CANADA - THANK YOU VERY MUCH.

L. Pazmany

Jim Neiswonger passed along this photo of the PL-2 prototype N1673 built by Harold Pio. After fling for 10 years it has been refinished and fitted with a set of wheel pants which look like they were designed by Paz, the same as on C-GQUK.

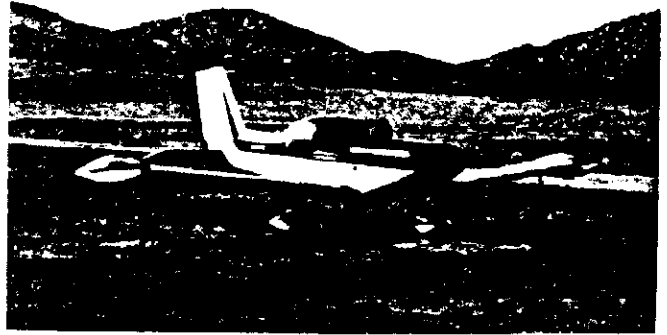

A new set of newsletter labels has been set up with a pair of numbers indicating subscription length. Example 66-69 indicates good through issues 66 thru 69. Although quite short and published on a pretty haphazard schedule, it is surprising how much time it takes. This should cut down some of the cursed book-keeping work which we all must cope with in our daily lives.

PAZMANY NEWSLETTER
Dave & Lib Panton
3565 Askin Blvd.
Windsor Ontario
Canada
N9E 3K1

LAOISLAC PAZMANY
PO Box 80051
SAN DIEGO
CALIFORNIA
92138

