

PAZMANY NEWSLETTER  
NUMBER 79  
2nd QUARTER, 1987  
Aircraft Designer:  
Ladislao Pazmany  
PO Box 80051  
San Diego, CA 92138

Rates: \$1.00/Issue  
(\$1.50 overseas)  
Editor:  
Jack McCombs  
656 Grand St.  
Oshkosh, WI 54901  
(414)426-3731

TIME FOR THE SECOND QUARTER EDITION of the PL newsletter. As I write this, it's still the second quarter (barely); July is still almost a week away. So with a little luck, and if I don't get too sidetracked with other projects, I may get this in the mail while it's still the second quarter. Speaking of projects, N75 PL is still not flying (yeah, I know it's been two years now) but I'm getting closer. A couple days ago I completed installation and adjustment of the turnbuckles (which I had to modify), and rudder pedals and nose wheel steering are now secure and safetied. I have a few more cotter keys to install, reinstall the front interior trim panels, assemble the parking brake mechanism, and modify and install the cockpit side trim panels. Once all this is done, I'll have to scout up a trusty AI mechanic to perform the annual, and hopefully she'll be back in the air before EAA Convention. I've had the time to get some work done on it lately, but as with all things, it always takes longer than you figured. Meanwhile, I've learned a lot - like next time, do it differently - and I guess that's what it's all about, right? Meanwhile, I've made up a couple sketches to show you how I did it; see page 2. By the way, I had previously included some sketches and text on this project on pp. 7-9 of newsletter # 73 (summer, 1985) so if this project really interests you, feel free to refer back to that info. All this started because I wanted dual brakes for each position in the airplane, and as I purchased the PL it was equipped only with brakes on the left set of pedals. I opted for the Cessna pedals due to (1) availability, (2) price, and (3) the fact that Cessna only uses one set of master cylinders with a concentric torque tube and linkage system to interconnect the right and left sets of pedals. I really was shy about installing a second set of master cylinders and shuttle valves, as some aircraft manufacturers do it; I just didn't like the idea of all the extra hydraulic lines, cylinders, and valves. However, such systems seem to work just fine for many manufacturers, so I guess you can't argue with success. If I were to do it over again, I'd remove the right pedals (without removing the torque tubes or attach blocks - that job became much more involved than I expected, when I had to remove the floor to get a wrench on the nuts to remove the blocks) and make up a set of brake pedals to attach to the tops of the right pedals, just as on the left set of pedals. Then I'd install a second set of master cylinders and shuttle valves between the respective cylinders. Actually, had I proceeded along that route, I'd probably be cursing that I didn't go the other way, but let's face it: Any way you cut it, it's a fairly involved job, installing dual brakes as a retrofit. Anyway, you can see a bit more about how I went about it on the next page and in newsletter 73.

Dear Paz-

I included the info. you sent way back <sup>1</sup> in March on (non) annealing Plexiglass. Should make a lot of builders happy to hear they needn't bother. Meant to include the article from Sport Av. on Ed Guther's wet wing PL (already checked w/staff for permission - no problem, of course) but ran out of room this issue. Next time for sure (I hope) - Jack M.

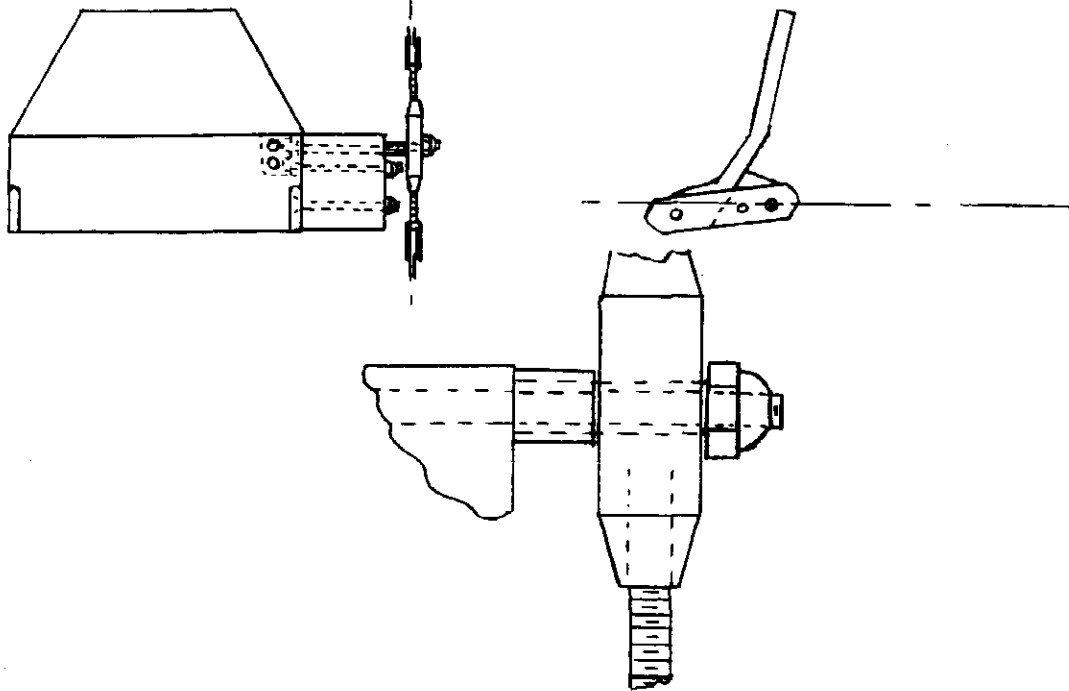

The upper left sketch is a top view of the right rudder pedal on the right side, showing the aluminum block fabricated to attach the cable turnbuckle to the rudder pedal. The left side is of course a mirror image of the right. The block was necessary to provide support for the bolt from rudder pedal to turnbuckle; otherwise there was too much bending stress on it, even though it was plenty strong enough in shear.

The upper right sketch is a simplified side view of the same thing, with turnbuckle and attach bolts omitted. The attach block has three bolts running through it, one through the "ear" on the side of the pedal and the other two through an angle that is in turn bolted to the back of the pedal. Lightening holes were machined between the bolt runs through the blocks. The attach bolt for the turnbuckle passes through the forwardmost hole in the block, because this position is closest to the pivot axis for the brake action. If the cable is attached forward or rearward of this pivot point, then the action of applying brakes would rock the top of the pedal forward, which would cause the rear of the pedal to rise and the front to drop. This would tend to move the cable vertically. As it is the two axes (rudder pivot and cable attach) are not concentric, but are close enough so that brake application sufficient to bottom out the master cylinder only moves the cable about 1/2 inch vertically.

The bottom sketch is a "close up" of the turnbuckle attach. The bolt is an AN-3, with a 3/16" i.d. steel tube slipped over the end, between the attach block and the nut to take compression loads between the nut and the block to tension the bolt properly.

The sleeve passes through the center of the turnbuckle, which has been drilled out. This way the turnbuckle can pivot on the tube as the pedal moves to eliminate bending loads on the forks. The larger diameter sleeve between the turnbuckle and the block is only a spacer, to prevent the turnbuckle from moving inward on the tube and possibly catching on the other attach bolts.

Why drill out the center of the turnbuckle for the attach bolt? Because this way I have some adjustment on each end of the turnbuckle to adjust all four cables in the system: Left and right rudder cables and left and right nosewheel steering cables, all with only two turnbuckles. Granted, this is a cumbersome way to make adjustments, since if one attempts to adjust one of the forks to the rudder cables without detaching the turnbuckle from the pedal attach bolt, one only succeeds in twisting (and therefore changing the length of) the rudder cable. The easiest way to make adjustments is to loosen the front fork (to the nosewheel steering cable). This will work, since (at least on N75PL) the attach clevis to the cable is held in place on the end of the cable not by a nicopressed cable eye, but by a ball fitting swaged on the end of the cable. This allows the assembly to pivot on the ball when the fork is loosened. Once this has been done, then the attach bolt between the turnbuckle fork and the rudder cable can be removed and the fork can be adjusted in or out as desired without twisting the cable or removing the turnbuckle barrel from the attach point. Actually, this is a case of "easier done than said", since the description is a bit wordy, and I became fairly accomplished at these adjustments while (attempting to) aligning nosewheel, rudder, and rudder pedals. Many, many MANY sessions of pulling the airplane while carefully watching the vertical fin to make sure you were pulling in a straight line - lining it up with something in the background - then trotting around to the back of the airplane only to find that no, that last two turns on the turnbuckle fork was too much, and now the rudder is over to the left instead of the right, etc., etc. But at least now it should be closer than it was, since a few years ago the mechanic towing N75PL to the hangar for its annual managed to turn the nosewheel past its limit stop and broke the weld at the nosewheel steering torque tube. Granted, it apparently didn't have very good penetration anyway. When it was rewelded, it was not perfectly centered up so when rudder and pedals were straight the nosewheel was off to the right just a hair. This made for some annoyance when landing since when the nosewheel would come down it would want to wander to the right, but it wasn't hazardous. Actually it made everything work out just right in a slight right crosswind, when you were holding just a touch of left rudder in a slight slip anyway. And the slight displacement of the pedals from true neutral when taxiing and on takeoff actually wasn't noticeable.

Still, it's nice to have the nose and tail perfectly aligned again, even though I ran out of adjustment for the pedals - and they're still off of neutral by about 1/2" to the right. Ah, well, I can live with it, I guess. At least the nosewheel and rudder agree with each other now. Anyway, that's the reason for wanting to be able to adjust each turnbuckle fork independently, so I could try to align all these components with each other.

Meanwhile, onward to other things. One thing that's been on my mind for quite a while is that it would really be nice to have some sort of insignia patch for shirts, jackets, caps, canopy covers, etc., etc. to advertise our PLs a bit more. A few months ago I started checking into this and drew up a 3 inch round emblem as shown below. The neat picture of the PL in the center is thanks to your previous newsletter editor, Dave Panton. Dave always used this neat little line drawing as the centerpiece for his headings on the newsletter, and sent them along when he passed the newsletter on to me. Matter of fact, I'd use them in my newsletters too, if I remembered to apply it before copying. Anyway, this is a slightly enlarged version of that drawing, fit into a circular patch as you can see below. This emblem is in color, too, with all edging and lettering in black, the outer ring with the words "Pazmany PL-1 PL-2" in white, the inner circular background for the airplane in sky blue, and the PL itself in silver gray metallic. (If your PL is painted, too bad. Mine's still in bare aluminum, mostly.) Anyway, I just received the completed batch of 50 of these embroidered emblems a week or so ago, and believe me, they really came out **NEAT!!** The cost on these came out to a little less than \$3.00 apiece, and in fact with postage comes out to within a fraction of a cent of being exactly \$3.00. This makes it most convenient if you'd like your very own PL emblems: Just send your newsletter editor \$3.00 per emblem and I'll get them off to you and cover the return postage. Or if you have sufficient funds in your subscription account, just let me know how many you want and I'll delete the appropriate number of issues (at three issues per emblem, or two issues/emblem if you're not in North America) from your subscription account.

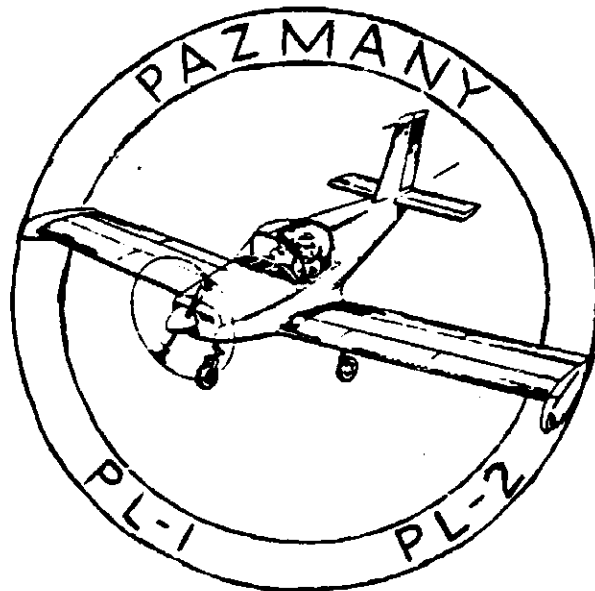

I wish I could have the newsletter copying done in color, so you could all see how these came out. The emblem is shown actual size, by the way. As they say on TV, "Not available in stores," so let me know. The first 46 lucky orders (Anne and I claimed the first four for our own jackets and caps) will receive theirs by return mail, but if these prove to be more popular than I

anticipated, it will be on the order of 6 weeks or so for them to make up another batch. These will not be the end of the supply; I will definitely make up more if there's sufficient demand. And by the way, if any of you can find a better deal on having these made up and want to make up a bundle for your own purposes, go right ahead, no problem. In fact, if any of you have any thoughts on changes to the design or whatever, let me know, and if there's sufficient demand for another batch, maybe I'll do it differently next time. But for now, get those orders in fast, and be the first kid on your block to have an OFFICIAL (whatever that means) PL emblem!

By the way, I've been toying with the idea of PL tie pins /lapel pins also, but haven't priced these yet. If any of you would like to show off your favorite airplane when you're all dressed up, this is the way to go, if we can keep the cost down. I've also thought about decals along the same lines as the embroidered emblems I now have, but again, I haven't checked out cost. If you have any thoughts on this, want to show off your PL on your car right next to your EAA decal, let me know and I'll check into it further. Get those orders in quickly, and display that PL emblem proudly at the EAA Convention!

Meanwhile, let's get into some catchup on back correspondence. I'm going to take these in chronological order, starting with a letter from your previous newsletter editor, Dave Panton. Dave wrote a nice long (3 pp.) newsy letter way back last Sept., and I've been meaning to note some of his comments in the newsletter for some time now - like about nine months or so. As most of you no doubt know, Dave and Libby are the proud owners of PL-2 #110, C-GQUK (they put funny letters on their airplanes in Canada - but then, you probably feel the same way about our U.S. numbers.) Dave now has somewhat over a thousand hours of flight time (1032 last Sept., to be precise) on Uniform Kilo and had written after making his first trip into OSH with UK during last year's EAA Convention. Wasn't all that bad, was it? Most pilots find after making that flight into OSH during the Convention that it really is easier than they initially thought it would be - so long as they do a bit of reading up on procedures beforehand.

Dave has done a little more cleanup on UK (flush screws - over 100! - aileron and flap gap seals, etc.) and reports that on last year's annual trip from Windsor to British Columbia and return, he averaged TAS of 127-128 mph., on 5 1/2 U.S. gal./hr. To me, this is excellent, since N75 PL will true out at identical optimum TAS (but my average would probably be a few mph slower on a long trip, due to less than optimum altitudes, etc.) but I have to burn exactly 6 gph to do it. On the other hand, I don't have those slick wheel and strut fairings that Dave has, either. Dave's are from Pete Karmouche, who you will recall went to the trouble to make female molds for all these components. Dave credits these fairings with a 14 mph speed increase! I'd love to have a set myself, but it always seems there's something else to spend my money on. Meanwhile, I'll hold you to that promise to run some further speed tests to compare with the numbers you came up with way back in '78. Let us know just how fast a really clean PL will go.

However, one drag reduction detail that Dave recommends NOT

performing is fairing the leading edge of the wing walk. Dave had tried this with some silicone sealant and found that the stall speed increased, by something on the order of 3-4 mph! Next question: Was this only an *indicated* increase, or was it verified by flying with another aircraft? I have a sneaking suspicion that the airflow was truly smoothed out with this modification, which resulted in a higher energy airflow over that area of the wing. With the pitot tube on the vertical fin, anything which would impart a higher energy (more relative speed) to the airflow close in to the fuselage might show up at high angles of attack on the airspeed indicator. In other words, it's possible that the stall speed wasn't really increased at all, but that the airplane stalled at a higher *indicated* airspeed due to the modification. I would think that anything that could be done to clean up the upper surface of the wing would improve the max lift coefficient, and therefore lower stall speed rather than raise it. The inverse is certainly true: dirtying up the lower surface slows the airflow, which means there is a greater difference in velocity between the flow over the upper surface and under the lower surface - and that difference in velocity is what creates lift. Check out the numbers for stall speeds on most retract gear aircraft, and you'll find that generally they are lower with the gear down dirtying up a localized area of the lower surface than with the gear up, all other things being equal. (Single engine Cessnas are a notable exception to this rule of course, since the gear retracts into the fuselage rather than the wing.) Normally, however, the difference in stall speed with gear up / gear down is only on the order of 2-3-4 mph, or about what you got from that minor cleanup on the wingwalk, Dave. I wouldn't have expected so much difference with such a minor change. On the other hand, maybe my theory is all wet and there's an entirely different explanation for all this. Anyone out there have any different ideas?

Dave also mentioned another fellow PL builder, WILL GULLACHSON of Kelowna, BC who as of last summer was getting close to completion on his PL-2. Will was a subscriber at one time, but I haven't heard from him for a while, so don't know what his current status is.

And finally, Dave commented on the constant questions and comments one receives when flying such a distinctive aircraft as a PL-1 or -2. Of course, the most frequent questions are "how fast does it go?" and "did you build it from a kit?" Love your reply: "Yes, but first I had to build the kit!" Thanks for the great letter, Dave, and I'll try not to take so long commenting on the next one.

Some few months ago I recieved a fascinating call from another subscriber and PL-2 flyer, Maj. Bob Hancock. Seems that Bob was out flying one day and had a midair collision with a chicken hawk (you might call it a red tailed hawk - same thing, as I understand). Bob was doing about 90 kts. at the time, and you can imagine the damage a one pound plus bird will do at over 100 mph! The impact point was on the left wing around stations 80 and 90, and in fact actually put a hole in the leading edge. Bob slowed to 80 kts. and found that the airplane was a bit sluggish at that speed, so picked it back up to 100 kts. where it

flew just fine. Fortunately, Bob has a bit less hassle landing at a military base than most of us would; he does it all the time in Uncle Sam's airplanes. So he opted to land at Robbins AFB (Georgia) where the runways are long and the crash trucks are plentiful, just in case. Final was flown at 90 kts. again, and the good old PL flew just fine right down into ground effect, whereupon Bob slowed gradually to 65 kts. and landed. As the airplane got slower and slower, he found more and more roll and yaw toward the damaged left wing, and at touchdown had full right aileron and rudder input. Nice job, and we're all very happy that you and N761W made it back in (almost) one piece. The result of all this, at least at the time Bob called, was that he was looking for the appropriate nose ribs for stations 80 and 90, left wing. These are part #s 2-10-005-1 and 2-10-005-2, according to my plans, the -1 nose rib flange being bent to the left and the -2 to the right. At the time Bob called me with his tale of woe he was in need of these parts, but that was a while back. On the chance that he may still need help on this, please give him a call at (912)926-2225 days or (912)923-7222 eves and weekends if you can help him out.

Back in March I received a letter from Duane Seymour and just a few days ago as I write this received yet another note from him, so I'll combine all his notes into one section here. First of all, you might recall that in the last newsletter Duane was looking for info and help on cooling baffles for his Lycoming O-320 installation and remote mount oil cooler installation. Well, these problems have been pretty much resolved. Duane borrowed a set of O-320 baffles from Tony Bingelis (who turns out the Sportplane Builder column monthly in Sport Aviation) and in fact has generously offered to provide a set of these templates on manila folder stock to any of you PL builders out there for FREE! My order is going in with this newsletter, since I someday intend to install an O-320 in 75PL. However, it might be nice to send along a contribution to cover postage for Duane; please send him a couple bucks with your order, since he's doing this out of the goodness of his heart for us.

Duane also solved the oil filter clearance problem with an O-320 by purchasing a remote filter adapter from J. C. Whitney - see below:

### Remote OIL FILTER CONVERSIONS

for American & Imported Cars, Trucks, RVs and 4WDs

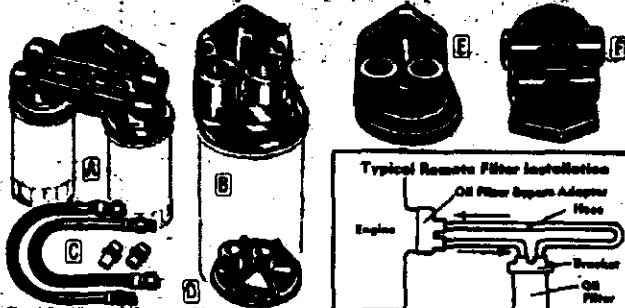

Shed 1-qt. or single 2-qt. filter conversion with:

- double oil filtering capacity
  - increase engine oil capacity
  - help cool engine oil
- Ideal for vehicles operating under extreme dust or severe work conditions. For a complete conversion, order bracket, filter(s), oil filter bypass adapter and hose kit sold below. Mount in engine compartment in any area that's easily accessible when changing filter(s).

**A** Bracket for remote dual 1-quart spin-on oil filter (not included—order below). Accepts Ford and Chrysler-type spin-on filters (not included—order below). Filters up to 8 gallons per minute. Overall size including filter: 4-1/2" deep x 7-1/2" long x 10" wide. **73XJ2363U**— Each \$16.18

Bracket for remote dual 2-quart spin-on oil filter (not shown). Same as above, except accept GM truck-type spin-on filters (not included—order below). **73XN7464R**— Each \$17.98

Our Best Spin-on Filters (not shown) for brackets above. **73XN9243U**—1-qt. (order 2) Each \$2.24  
**84XN6627R**—2-qt. Each 5.38

**B** Bracket for remote single 2-quart spin-on oil filter. Accepts GM truck-type spin-on filter (not included—order below). Filters up to 12 gallons per minute. Overall size including filter: 4-1/2" deep x 10" long x 4-1/2" wide. Die-cast aluminum alloy. **84XJ6636A**— Each \$7.18

Our Best 2-quart Spin-on Filter (not shown) for bracket above. **84XJ6627R**— Each \$5.38

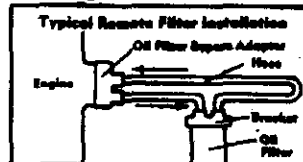

- C** Hose and Fitting Kit. 1/2" I.D. neoprene hoses with precision brass ends and fittings. Hoses come with necessary hardware to complete remote filter bracket and oil filter bypass installation. Kit includes 2 hoses, 4 fittings, 2 nipple connectors. **73XJ2363B**—24" long 1-KH \$17.98  
**73XJ3962P**—36" long 1-KH 19.78  
**73XJ3963Y**—48" long 1-KH 22.48

**D** Oil Filter Bypass Adapter. Specifically designed for use with our remote oil filter brackets, but can also be used in the installation of oil coolers and other oil system accessories. **Wesco Gaskets, Stone Metals, Ross Metals, Cyl. No. Engine Stop, Spin-on or Conister-type Filter and S&K. No. Note The S&K. No. you ordered may carry a different identification no. on your pkg.**

For American Cars & Trucks	
80-86 AMC	60-86 Cadillac
Alliance	56-86 Chevrolet
Jeep®	59-86 Olds
59-86 Buick	50-86 Chrysler
<b>55XJ3270P</b> —	Dodge
	60-86 Pontiac
	Each \$8.99

For Imported Cars & Trucks **55XJ3262X**— Each \$5.84

**E** & **F** Oil Filter Brackets. Act as a remote base for Ford and Chrysler-type 1-quart spin-on filters (not included—order below). Made of cast aluminum. Choice of vertical or horizontal inlet/outlet. **84XJ6625T**—Vertical Each \$5.38  
**73XJ6637W**—Horizontal Each 13.08

Our Best 1-quart Spin-on Filter (not shown) for brackets above. **73XJ9243U**— Each \$2.24

Duane sent this ad along in his letter, but I checked the current catalog I have (they send them out every few weeks) and the prices are identical. This ad has a bit more information, however, so I copied it rather than the current one. See p. 207 of the current catalog, or it will be within a few pages of that in any of the older ones of the past year or so. As any of you know who have ever ordered anything from them in your life, you'll be on their mailing list forever, so I imagine most of you have a catalog from them. If not, you can write to J. C. Whitney at 1917 Archer Ave., Chicago, IL 60680, or give them a call at (312)431-6102. They don't seem to have a toll free number. I personally have found that they're pretty good about refunds, too, if you decide to return an item. Duane is using the "E" model adapter on the firewall, with the oil cooler plumbed downstream of the filter. He's mounting the cooler on the engine mount, with a separate fiberglass duct to bring in air from an opening in the nose bowl. Speaking of the nose bowl, Duane decided to use one from a Grumman Tiger. These are available through Wag-Aero, Lyons, WI, who bought up all the remaining parts when Grumman dropped their general aviation line. The Tiger is a 180 hp airplane though, powered by a Lycoming O-360. I wonder if the nose bowl for a Traveler/Cheetah (O-320 powered) might not be a better fit. I don't actually know how much difference there is between the two nose bowls, however.

Now, however, Duane has a couple new problems. First of all, back when he purchased his O-320 he also picked up an exhaust system - which he now finds does not fit inside the cowling. Apparently the system was out of a Piper Cherokee, which has a somewhat larger nose bowl and cowling than the PL. Identification is as follows: Elano Corp., Xenia, Ohio, P/N 025-360-002, and Piper A/C P/N 78463-1, 2-74. The reason I'm listing all this info is that Duane wants to make an even up trade of this system (it's stainless, by the way) for a stainless two stack system for the PL-2 w/O-320 D1A, if anyone is interested. Duane also has two Delco generators, model 1101913 (35 amp) and 110915 (50 amp). He needs the appropriate Delco voltage regulator, #1118704 (35 a.) or 1118713 (50 a.) or a Prestolite VSF 7203-5 (35 a.) If you want a generator and have the appropriate voltage regulator for him, Duane is willing to trade straight even - or you can have both generators for a new alternator and voltage regulator.

Duane is also curious as to what builders are using to attach the plexiglass to the canopy and windshield frames; apparently the PS-18 cement from Rohm & Haas is no longer available, at least through the company called out on my plans - Industrial Polychemical Service, 17116 S. Broadway, Gardena, CA. I would assume that since Rohm & Haas is still in business, you could contact them; I don't have an address, but check the local library for an industrial guide of some sort, and they should be able to come up with something. If you can help Duane out on any of the above, contact him at 210 Rue Grand, Lake St. Louis, MO 63367; phone (314)872-2744 days, (314)625-1039 eves and weekends.

Speaking of plexiglass, you might recall some questions from Pete Karmouche on annealing plexiglass, and some thoughts I had on the subject. Well, not long after sending out that newsletter

I received a letter from Paz himself stating that he had never heard about annealing plexiglass - and with all the windshields, canopies, and etc. he's personally made for various aircraft - all the PL series and the Ryson Cloudster - he's never annealed the plexiglass for any of them. Paz went so far as to contact Rohm & Haas, who confirmed this: There is NO annealing required for plexiglass! Paz was also kind enough to pass this info along to Pete K., but I thought I'd throw it in here so the rest of you won't stay awake nights worrying about it now.

Would you believe that there are still people ordering plans and starting construction of PL-2s out there? It's true! Not long ago I received a letter from James A. Daniel, 2985 Comanche Ct., Alamogordo, NM 88310. Jim just purchased his plans last August while on a trip to San Diego, so is just getting underway. Welcome aboard, and good luck with the project. Keep plugging away at it; it's worth it, as any who have completed a PL will tell you. Here's hoping you may glean some useful hints from the newsletter; if you run into any snags, drop me a line and we'll bring it up to the rest of the group. Somewhere out there there's someone who has run into a similar problem and resolved it, no doubt. That's one of the things we're here for.

Speaking of help, Lee Conlan wrote to let everyone know that yes, he's still in the PL parts business, through the end of this year. If you'd like Lee to fabricate any parts for you, let him know NOW. He'll be taking orders to the end of the year, at which time he'll finish up any unfinished orders and get them out. Lee wants no money yet; he'll let you know when your order is ready and requests payment be sent then, prior to shipping. However, Lee will be working at his own schedule, so don't bug him. If you're still building, you can no doubt find lots of other things to work on while you're waiting for that order to be completed anyway, right? If I had room I'd include the info sheet from Lee's company, Homebuilder's Aircraft Associates. Manwhile, if you need anything contact him at 7858 Arnett St., Downey, CA 90241; phone (213)869-0536.

And just a couple weeks ago as I finish this issue up, Bob Bradley sent along a nice letter to let us know how his PL-1 is doing. You might recall that Bob just finished up his PL-1 last fall, and being an engineer type, had installed various innovations - which seem to be working out quite nicely. Bob has installed hydraulic flaps powered by a hand actuated pump, which really cuts down on the muscle needed to extend the flaps. He now has to apply all of about two pounds of pressure on the handle, with seven strokes for full flaps. The automatic fuel control is working fine; Bob designed this device to eliminate assymmetric fuel loads. So far, from his letter, the biggest problem Bob has had is finding good flying weather - welcome to the real world! Oh, well, it's bound to turn around one of these days, and you'll be able to go up and bore holes in the air to your heart's content.

There are still other things I'd like to include but it looks like they'll have to wait till issue #80. You can look forward to that one sometime after EAA Convention. It looks as though I'll have sufficient news to discuss next time around; I've still got items I've intended to include in the last issues!

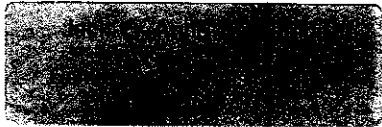

---

Ladislao Pazmany  
P.O. Box 80051  
San Diego CA 92138

Your last issue is #N/A