

# ENGINEERING CHANGE NOTICE #6

MAY 1967

DWG 1-30.006

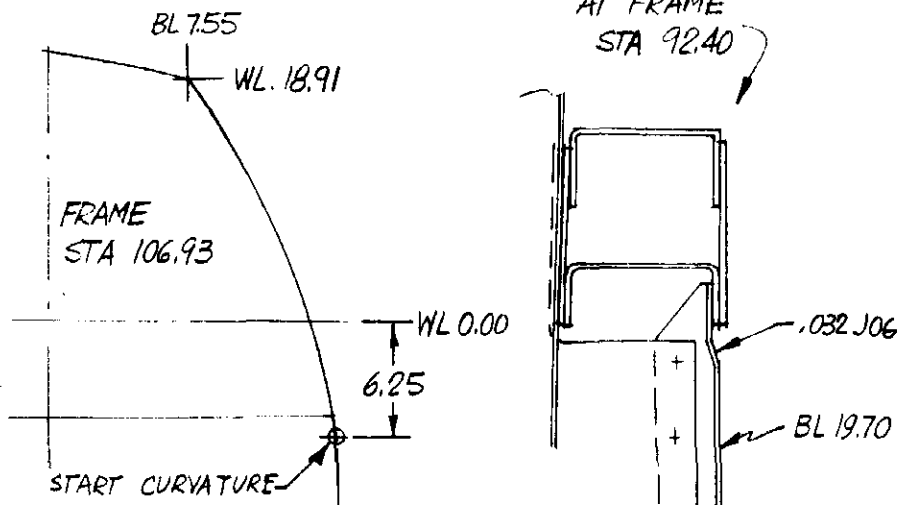

DWG 1-30.005

AT FRAME STA 205.00  
SHOW JOG AT EACH CORNER

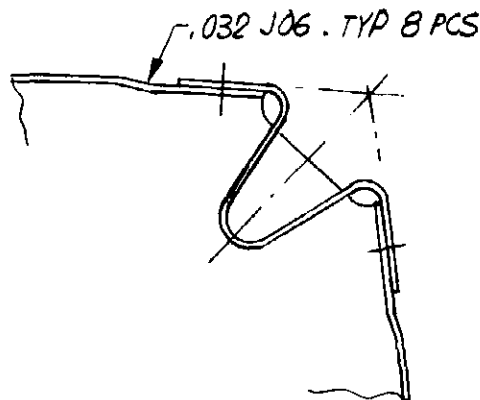

DWG 1-50.008

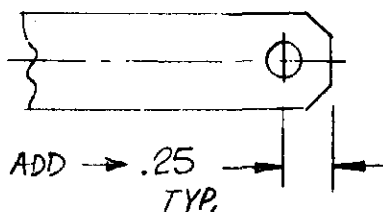

INNER & OUTER SUPPORT

PAGE 19 OF INSTRUCTIONS

ADD NOTE: DRAIN HOLES, DRILL .250 DIA HOLES AT THE LOWEST POINTS OF THE STRUCTURE FOR DRAINAGE.

DWG 1-10.002

AT BOTTOM LEFT CORNER ADD NOTE: TORQUE NAS 1104 AND NAS 1204 BOLTS TO 69 IN x LBS

PL-1 NEWS LETTER NO 6

1. INCORPORATE CHANGES SHOWN IN THIS PAGE (ECN #6)

2. I JUST FINISHED THE FUEL SYSTEM INSTALLATION FOR THE PL-2. THIS DWG IS 99% APPLICABLE TO THE PL-1.

3. I MADE SOME CHANGES IN THE ELECTRICAL SYSTEM SCHEMATICS. I WILL SEND YOU FREE A NEW PRINT IF YOU MAIL ME THE OLD ONE, AND A SELF ADDRESSED AND STAMPED (20¢) ENVELOPE. IF YOU STILL DO NOT HAVE THIS DWG YOU CAN ORDER IT FOR \$3.00.

4. I ALSO JUST FINISHED THE WINDSHIELD AND CANOPY DWG FOR THE PL-2. THIS IS A COMPLETE REDESIGN USING FIBERGLASS FRAMES INSTEAD OF BUILD-UP SHEET METAL, ALSO A BETTER WAY OF ATTACHING THE GRANT SLIDE, AND A DESIGN FOR CANOPY LATCH AND LOCK. UNFORTUNATELY THE FULL SIZE LOFT LINES WILL NOT FIT THE PL-1, BUT YOU MIGHT BE INTERESTED IN THE OTHER FEATURES. YOU CAN ORDER THIS DRAWING FOR \$6.00 (IT IS A BIG ONE, 18.5 SQ FT).

5. THE SECOND PL-1 IS FLYING NOW. WITH THE 125 HP LYC. BUILT IN CANADA YOU CAN SEE IT AT ROCKFORD IN THE NEXT FLY-IN

HAVE FUN! *A. Pajmanny*

DWG 1-10.001

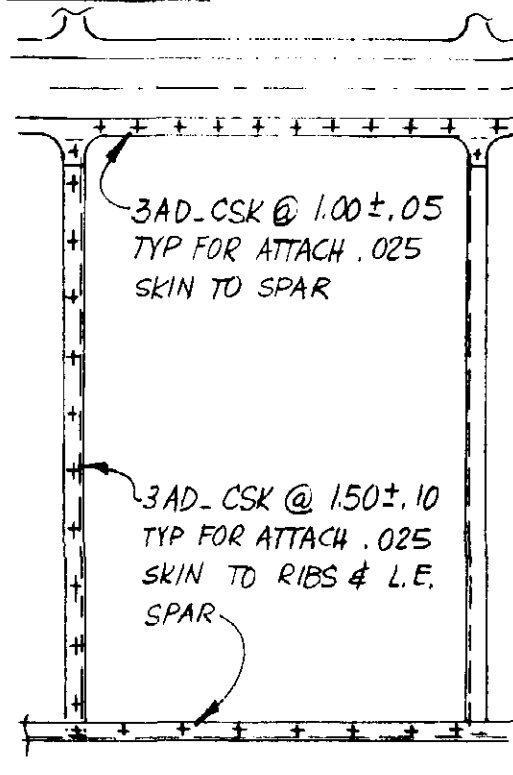

DWG 1-30.003 (BOTTOM LEFT CORNER)



ADD .55x.55x.040 ANGLE TO SUPPORT 1/4" PLYWOOD FLOOR. ADD ALSO ONE NAS 333-4 BOLT AND ONE KAYNAR F-1934-3-2 ANCHOR NUT

DWG 1-30.009

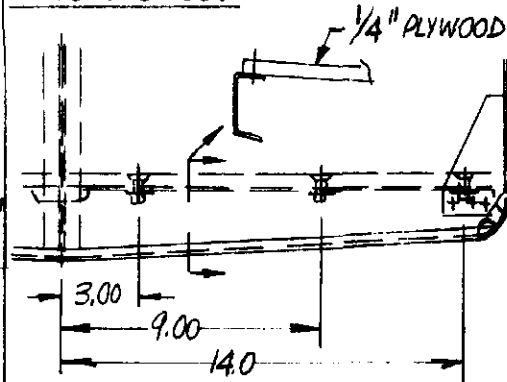

SHOW PLYWOOD FLOOR AND NAS 333-4 BOLTS AND KAYNAR F-1934-3-2 ANCHOR NUTS PROVIDE CUTOUTS IN FLOOR TO CLEAR RUDDER PEDALS AND SUPPORTS

## OPTIONAL DRAWINGS

<u>Dwg. No.</u>	<u>Used On</u>	<u>Title</u>	<u>Sq. Ft.</u>	<u>Price</u>
1-30-011	PL-1	Fuselage Tail Cone Frames - Loft Lines	6.6	\$3.00
1-40-009	PL-1	Engine Mount for Lycoming 0-290-G	11.6	4.00
1-40-010	PL-1	Firewall for Lycoming 0-290-G	9.6	4.00
2-70-001	PL-2	Electrical System Schematic	4.2	3.00
2-40-006	PL-2	Power Plant Details	12.2	4.00
2-40-007	PL-2	Exhaust System	13.5	4.00
2-40-008	PL-2	Cowl Installation	14.0	4.00
2-40-005	PL-2	Engine Installation	13.0	4.00
2-40-009	PL-2	Nose Cowl (fiberglass)	18.7	6.00
2-70-002	PL-2	Brake System Installation	10.0	3.00
2-40-010	PL-2	Fuel System	11.5	4.00
2-30-004	PL-2	Windshield and Canopy	18.5	6.00

- Dwg. 1-30-011 Is a full size drawing very helpful to lay out the templates for the tail cone frames.
- Dwg. 1-40-009 Is a new design for the alternate Lyc 0-290-G or any of the Lycoming 4-cylinder engines.
- Dwg. 1-40-010 Is also a new design, incorporating some strengthening due to the heavier weight of the Lycoming engines.
- Dwg. 2-40-006 Power Plant Details show: Spinner (fiberglass), spinner plates, carburetor heat box assembly, propeller spacers.
- Dwg. 2-40-007 Shows the cross-over exhaust for the Lycoming 0-290-G with mufflers and heaters in every detail. The cross-over exhaust will increase the performance of the engine by approximately 4%.
- Dwg. 2-40-008 Shows the cowl for the Lycoming, including cowl flap.
- Dwg. 2-40-005 Shows the major components and most of the hardware required for the assembly.
- Dwg. 2-40-010 Fuel system - shows lines, valves, fittings, auxiliary pump, primer, pressure gage.

Every part of these drawings has a dash number, and each drawing has a parts list which indicates materials, heat treatments, raw sizes, specs, suppliers, etc.

For those who are using the Lycoming engine, I have prepared a weight and balance (2 sheets) which can be ordered for \$1.00