

SAN DIEGO — CALIFORNIA —		MODEL NO.	
CHECKED	8-75	REPORT NO.	
APPROVED		PAGE NO.	1
ENGINEERING CHANGE NOTICE 2			

## FABRIC COVERING

THE PL-9 AIRCRAFT IS ALMOST ENTIRELY FABRIC COVERED EXCEPT HORIZONTAL AND VERTICAL STABILIZER, AND FIBERGLASS FAIRINGS.

THE STITS POLY-FIBER SYSTEM IS SUGGESTED. OBTAIN FROM STITS POLY-FIBER AIRCRAFT COATINGS: P.O. BOX 3084 - RIVERSIDE, CALIFORNIA - 92519-3084. SAMPLES OF ALL MATERIALS AND REQUIRED MANUALS (NO CHARGE) - ALSO A 2 HOURS VIDEO TAPE. PERSON TO CONTACT: MR JOHN GOLDENBAUM. PHONES: 1-800-362-3490 - (909)-684-4280 - FAX (909)684-0518

THE MATERIALS AND QUANTITIES REQUIRED ARE AS FOLLOWS:

- 60 YARDS P 103 FABRIC
- 13 GAL POLY-BRUSH
- 17 GAL POLY-SPRAY
- 1 GAL POLY-TACK
- 7 GAL POLY-FIBER (REDUCER)
- 17 GAL POLY-TONE PIGMENTED FINISH } ALTERNATES
- 12 GAL AERO-THANE FINISH }
- 1 ROLL 1" PINKED TAPE
- 6 ROLLS 2" " "
- 1 ROLL 3" " "
- 1 ROLL STD RIB CORD
- 2 ROLLS REINFO. TAPE
- 100 DRAIN GROMMETS
- 10 INSPECTION HOLE RINGS & COVERS

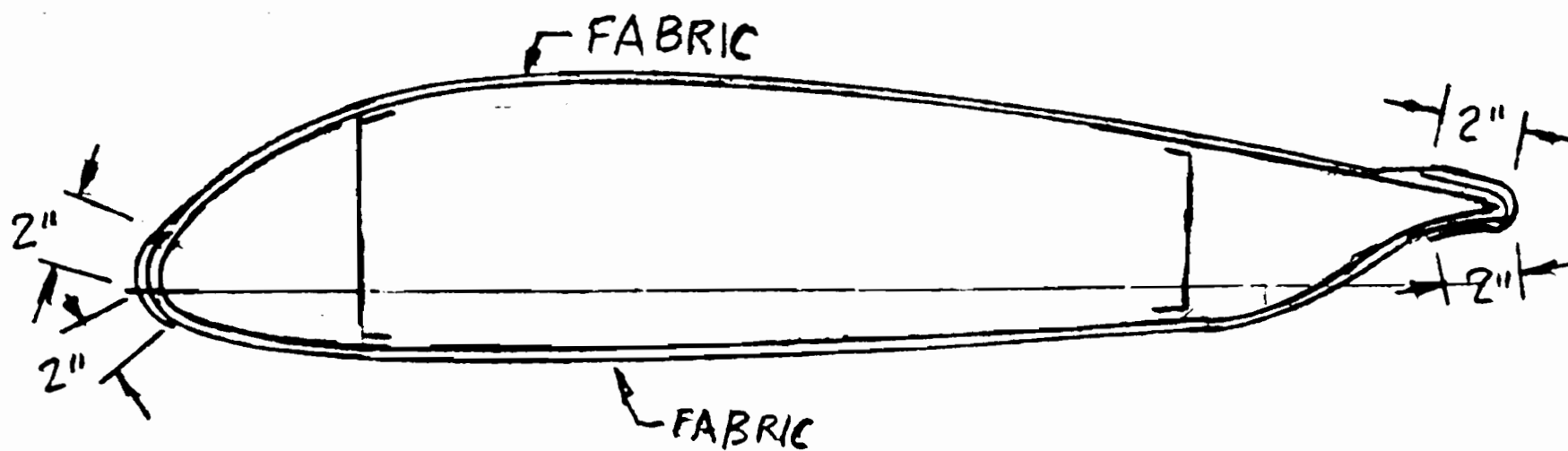

OVERLAP THE TOP & BOTTOM COVER AS SHOWN - SEE STITS MANUAL FOR MORE DETAILS. COAT THE SHEET METAL LEADING EDGE & TRAILING EDGE WITH EPOXY PRIMER BEFORE CEMENTING THE FABRIC COVER.

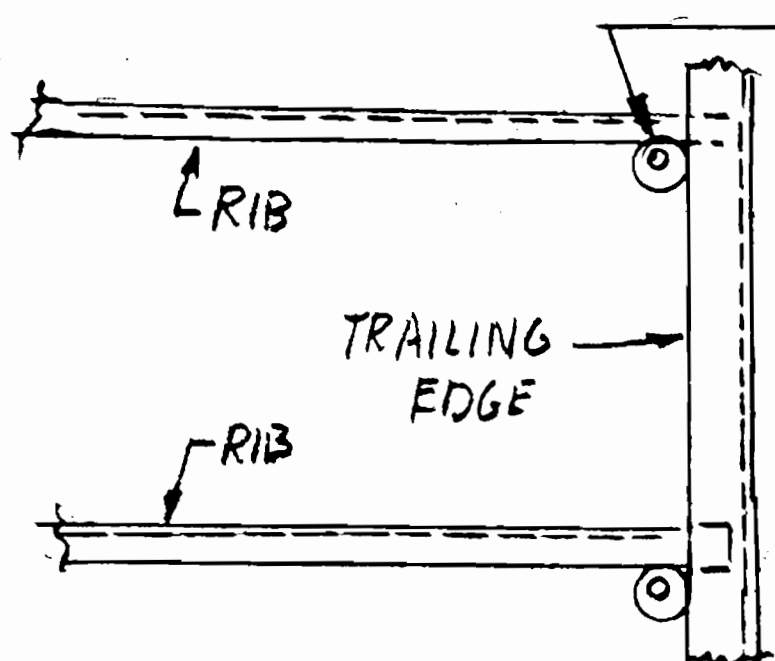

CEMENT DRAIN GROMMETS AT THE TRAILING EDGE BESIDES THE RIBS - TYPICAL AT THE WING BOX, FLAPS, ALLERONS, ELEVATOR AND RUDDER.