

Gentlemen PL-1 Builders:

HERE WE ARE ONCE AGAIN WITH A FEW IDEAS AND ITEMS THAT I'M SURE WE'LL BE OF HELP TO SOME OF OUR BUILDERS IF NOT ALL. WE ARE A LITTLE LATE BUT I HAVE BEEN WAITING ON A LITTLE MORE INFORMATION AND A COUPLE OF ITEMS ON SHEET METAL BRAKES TO BE PRINTED. SO HERE GOES WITH THE DOPE I HAVE COLLECTED OVER THE PAST FEW WEEKS TO PASS ON THE WAY TO YOU.

MR. DARRELL YENNEY - 12417 SHIRLEY ST. OMAHA, NEBRASKA IS TOOLING UP TO MAKE LANDING GEAR PARTS AND WOULD LIKE TO SWAP PARTS FOR LANDING GEAR FOR VARIOUS FIBERGLASS PARTS. DARRELL HAS HIS OWN HOME MACHINE SHOP AT HOME AND IS A TOOL AND DIE MAKER BY TRADE AND THESE TOOL AND DIE MAKERS DO SOME BEAUTIFUL WORK. I'M SURE DARRELL WOULD APPRECIATE HEARING FROM YOU PRETTY SOON.

MR. J. M. DWIGHT - P.O. BOX 929 - ARIZONA WESTERN COLLEGE - OR ROBIN LANE, #8 - YUMA, ARIZONA WAS KIND ENOUGH TO OFFER HIS ADVICE ON THE LATEST PROCESSES, CURRENT SETTINGS, AND TYPE OF FILLER METALS TO USE TO IN YONE DOING WELDING ON THE PL-1. JUST MAKE A REQUEST TO THE ABOVE ADDRESS AND HE WILL GLADLY OBLIGE. I'M SURE THIS WILL BE APPRECIATED BY MANY.

OUR GOOD FRIEND MR. DICK POSTON - 1850 DENVER ST. - SAN DIEGO, CALIF. HAS IN ADDITION TO A COMPLETE HARDWARE LIST, THE FOLLOWING
(1) ONE SET OF LANDING GEAR (COMPLETE) - \$800.00 (2) STABILATOR \$225.00 (3) FIN AND RUDDER (COMPLETE) \$225.00 (4) TIP TANKS (90% COMPLETE) \$300.00 (5) CAB. AIR BOX (FOR G-290) \$30.00 (6) STICK CONTROL (6) SHIMMY DAMPER \$30.00 (7) Assorted small parts.

DICK ALSO IS TAKING ORDERS FOR THE FLEX CABLE FOR OUR PARKING BRAKE. HE NEEDS AT LEAST 25 ORDERS TO HOLD THE PRICE DOWN TO \$14.00 PLUS POSTAGE OR PRICE FOR 1 SET COULD COST AS MUCH AS 75 BUCKS. SOUNDS LIKE A GOOD DEAL.

DICK ALSO SAYS HE WILL GET THE TUBING FOR THE LOWER FITTINGS FOR THE LANDING GEAR IF HE HAS SEVERAL REQUESTS FOR SUCH. ONE SET WOULD BE TOO EXPENSIVE DUE TO THE CUTTING CHARGE. MACHINE CRAFT OF TROY, OHIO APPARENTLY DOESN'T HAVE THIS.

ALSO DICK HAS 3 OIL SUMPS ON HAND FOR THE G-290-0 AT \$60.00 EACH PLUS POSTAGE, A FEW STARTERS AND STARTER RING GEARS. COME ON FELLOWS FOR THE HARDWARE AND ITEMS MENTIONED ABOVE CHECK WITH DICK AS HE HAS APPARENTLY GONE TO A LOT OF TROUBLE TO GATHER UP THESE PARTS JUST FOR PL-1 BUILDERS.

ONE MORE ITEM I'M SURE DICK STILL HAS IS THE ALUMINUM BRONE FOR A FULL SET OF LANDING GEAR FOR \$22.50 PLUS POSTAGE.

FOR PRICES ON HIS PARTS LISTED ABOVE THAT WE DON'T HAVE, DROP HIM A CARD. HE WILL GLADLY SEND YOU A PRICE LIST. KEEP UP THE GOOD WORK DICK.

WE HAVE ONE SOURCE FOR PARTIAL SHEETS AND THE HEAVIER BLOCKS FOR THE LANDING. THE ADDRESS IS: CENTRAL STEEL AND WIRE CO. - P. O. BOX 5310A - CHICAGO, ILL. - 60680. THERE IS A \$5.00 CUTTING CHARGE PLUS MATERIAL FOR EACH PIECE.

WE HAVE HAD SEVERAL REQUEST LATELY FOR INFORMATION ON THE FIBERGLASS RESIN AND MATERIALS NEEDED IN FIBERGLASS WORK. DOES ANY OF OUR BUILDERS KNOW WHERE WE CAN GET ENOUGH FOR JUST ONE PL-1 AS THIS IS ALL MOST BUILDERS WOULD WANT. IF SO, PLEASE LET ME KNOW AND I WILL PUBLISH IN THE NEXT LETTER.

MR. BILL GOFF - 3235 DAWG RD. - STOW, OHIO SAYS A SKIP TOOTH 6 TEETH PER INCH BLADE ON A CRAFTMAN 108 BAND SAW DID A FINE JOB ON SPLITTING HIS SPAR CLIPS. THE BLADES COST ABOUT \$2.37 EACH AND THIS GOES TO SHOW IT CAN STILL BE DONE BUT JUST TAKES TIME AND PATIENCE. BILL GOFF AND BOB TODD ARE WORKING TOGETHER AND SEEM TO BE MAKING A LOT OF PROGRESS.

MR. GEORGE M. HAWKS - 1096 ALBERDAN CIRCLE - PINOLE, CALIF. - 94564 HAS ONLY RECEIVED ONE ORDER FOR GRANT SLIDES FOR CANOPY AS OF MY LAST LETTER. THIS PRICE OF \$ 20.00 JUST CAN'T BE BEAT ANYWHERE EVEN WHEN YOU CAN GET THEM. APPARENTLY REASON FOR LAGGING ORDERS IS THAT FEW PEOPLE REALIZE HOW HARD THIS ITEM IS TO LOCATE EVEN AT PRICES UP AROUND \$ 40.00. PLEASE THINK THIS OVER AS WE MIGHT NOT GET ANOTHER CHANCE LIKE THIS. CLOSING DATE FOR THESE IS ABOUT THE LAST OF JUNE. JUST SEND GEORGE A MONEY ORDER AND HE WILL HOLD UNTIL HE PUTS ORDER IN.

DO WE, BY ANY CHANCE, HAVE ANYONE THAT WORKS FOR COMPANIES THAT MAKE AIRCRAFT PARTS SUCH AS WHEELS AND TIRES AND SO FORTH THAT WE MIGHT USE AND GET AT FAIRLY GOOD DISCOUNTS?

GEORGE HAWKS ALSO HAS SCOTT MODEL 4408B MASTER CYLINDERS THAT COULD BE USED ON THE PL-1 FOR \$ 4.00 EACH. THESE ARE THE L-19 TYPE SURPLUS.

GEORGE ALSO SAYS HE CAN GET YOU ALL THE BEARINGS, ROD ENDS, AND PULLEYS FOR AROUND \$ 50.00 BUT WILL TAKE A LITTLE TIME. SO IF YOU ARE INTERESTED, CONTACT GEORGE AS SOON AS POSSIBLE. THEY ARE TAFFIR MAKE

GEORGE ALSO SAYS ANOTHER SOURCE FOR BEARINGS IS: RUART BEARING CO. - 4525 W. JEFFERSON BLVD. - LOS ANGELES 16, CALIF. THESE BEARINGS WILL COST PROBABLY UPWARDS OF \$ 100.00 IF WE DON'T TAKE ADVANTAGE OF THIS OPPORTUNITY PRETTY SOON AS THIS SUPPLY MAY NOT LAST LONG.

GEORGE HAS ANOTHER SOURCE FOR FIREWALL MATERIAL & PRICE SOUNDS GREAT. A PIECE 36 " X 36" X .016" FOR \$ 1.82 AND THIS INCLUDES TAX BUT NOT POSTAGE. THESE ARE STAINLESS STEEL LITHOGRAPH PLATES BUT ARE UNDAMAGED IN ANY WAY. COULDN'T LOSE MUCH. GEORGE SAYS SEVERAL BUILDERS IN HIS AREA ARE USING THESE.

ONE SLICK IDEA GEORGE HAS COME UP WITH IS HOW TO GET THE USE OF A LATHE. ENROLL IN A NIGHT SCHOOL CLASS (MACHINE SHOP COURSE) & AFTER GETTING SITUATED SNEAK A FEW OF YOUR PIECES IN. SLICK TRICK IF YOU CAN DO IT. THANKS A MILLION GEORGE.

AND LAST BUT NOT THE LEAST IS A LETTER FROM OUR FRIENDS FROM MEXICO STATING THAT FOR \$ 200.00 THEY CAN FURNISH THE MATERIAL AND MACHINE THE 4 SPAR CAPS, 2 SPLICE BARS & 4 CENTERLINE T BARS FOR THE SPAR. THIS IS UNDRILLED.

CARIOS STATES IF THEY WILL FURNISH MATERIAL AND MACHINE AND DRILL THE COMPLETE SPAR FOR AROUND \$ 700.00 OR \$ 750.00. THIS IS INSTANT AND READY TO RIVET FOR THIS PRICE.

CARIOS HAS ASKED ME TO CHECK WITH YOU FELLOWS TO SEE JUST WHAT YOUR OPINION IS ON THESE PRICES. TRY TO GIVE HIM YOUR HONEST OPINION ON THESE ITEMS ABOVE. PLUS PRICE LIST ON THE LANDING GEAR PARTS, CONSIDERING THEIR INVESTMENT OF COSTLY MACHINERY TO DO MANY OF THEM. PLEASE SEND YOUR OPINION TO ME OR DIRECTLY TO: CARIOS SUAREZ LEZAMA, AERONAUTICA ESPECIALIZADA, 3 A. CALZADA ARBOLES GRANDES, 478, AEROPORTO CENTRAL, MEXICO 9. D. F., MEXICO.

I'M SURE THESE PEOPLE WILL APPRECIATE THIS VEPLY MUCH. THANK YOU GENTLEMEN.

THAT JUST ABOUT CONCLUDES OUR GET TOGETHER FOR THIS TIME. HOPE THIS LETTER IS WORTH THE SLIGHT DELAY AS WE TRY TO PUBLISH ONCE A MONTH DEPENDING ON MATERIAL TO BE PUBLISHED TIME TO PUT INTO IT. I HAVE BEEN DOING QUITE A BIT OF TIME RECENTLY ON MY FIBERGLASS TIP TANK BODS. AS SOON AS I FINISH AND MAKE THE FIRST SET I AM PLANNING ON OFFERING TO MAKE SEVERAL SETS PROVIDING THEY TURN OUT NICE. THIS SEEMS TO BE A HEADACHE FOR MOST BUILDERS.

ONE MORE THOUGHT IS TO BE SURE TO CHECK WITH MR. PAZMANY IF YOU PLAN TO MAKE MORE THAN ENOUGH PARTS FOR ONE PL-1. I DON'T THINK HE WOULD OBJECT AS LONG AS YOU MAKE THEM FOR SOMEONE WHO HAS RYXKXY PLANS.

ALSO CHECK WITH YOUR LOCAL CUSTOMS AGENT ON IMPORT TAX AND BEST METHODS OF SHIPMENT BEFORE BUYING MATERIALS FROM OTHER COUNTRIES. SUCH AS L. G. PARTS FROM MEXICO. THIS COULD SAVE A LOT OF TROUBLE IF YOU WOULD HAVE MATERIAL SHIPPED DIRECT TO THE AGENT AND WOULD BE MUCH QUIKER, I THINK.

OUR MANY THANKS SHOULD GO OUT TO MR. HARLIE D. REYNARD - 5248 39th ST. SO. - ST. PETERSBURG, FLA., 33711 FOR DOING THE SKETCH WORK ON OUR SHEET METAL BRAKES CONTAINED IN THIS LETTER. HARLIE HAS JUST PURCHASED A SET OF PLANS AND IS JUST GETTING STARTED. I'M SURE HE WOULD APPRECIATE ALL THE HELP THAT WE CAN GIVE HIM.

SEVERAL PEOPLE HAVE MENTIONED SOMETHING ABOUT HARDWARE AND ITEMS FOR FUEL SYSTEM SUCH AS TUBING AND MANY EXPENSIVE ITEMS IN THIS AREA THAT DICK MIGHT NOT HAVE IN STOCK. SO, IF YOU LET HIM KNOW YOU ARE INTERESTED IN FUEL SYSTEM ITEMS, HE CAN GET AN IDEA HOW MUCH TO PURCHASE. REMEMBER THE MORE PURCHASED AT ONCE, WILL BE CHEAPER. QUANTITY BUYING ALMOST ALWAYS PAYS OFF.

ALSO, HOW ABOUT THE N. A. S? HARDWARE FOR SPAR? (BOLTS, NUTS, FOR SPLICE MAINLY.)

DOES ANYONE KNOW OF A SOURCE TO PURCHASE FIBERGLASS, RESIN, & SLOSH COMPOUND AT FAIRLY GOOD PRICES AS I WILL BE GETTING INTO THIS SHORTLY?

BILL HAS SEVERAL BOXES OF MS-20426AD3-7 RIVETS. IN ENGLISH THIS IS 3/32 X 7/16" lg. - 100° COUNTERSUNK, HEAT TREATED AND ANODIZED FOR 3.00 a lb. POSTAGE PAID. PRETTY GOOD DEAL.

ALSO BILL HAS A COMPLETE SET OF DIES FOR WING RIBS AND WILL MAKE A SET FOR \$375.00 AND FURNISH THE MATERIAL IF HE CAN GET AT LEAST 6 PEOPLE INTERESTED. THESE RIBS WILL BE HYDROFORMED.

ANOTHER ITEM I WAS JUST ABOUT TO FORGET IS THE CADMIUM PLATE ON LAND GEAR. UNLESS THERE IS A SHOP IN YOUR AREA THAT HAS CONTROLLED CONDITIONS TO WORK UNDER YOU MIGHT COME OUT BETTER NOT TO CAD. PLATE THE TUBE. THESE BEST CONDITIONS ARE USUALLY FOUND IN THE LARGER SHOP IF A FIRST CLASS CADMIUM PLATE JOB IS NOT DONE, THIS CAN ACTUALLY CAUSE RUST.

ONE ALTERNATIVE - ACCORDING TO MR. DICK POSTON IS TO SIMPLY CLEAN THE TUBE GOOD AND USE A RUST PROOF PAINT. ONE GOOD MAKE ACCORDING TO DICK IS CALLED RUST-O-LEUM AND IS AVAILABLE MOST EVERYWHERE. DICK SAYS THIS PAINT HAS A FILLER PLUS A GALVANIZING ACTION.

DICK IS ALSO IN PROCESS OF SELLING OF ~~ELECTRICAL SWITCHES AND~~ CIRCUIT BREAKERS AND WILL SET UP A. N. PARTS FOR THE FUEL SYSTEM WHEN THERE IS A DEMAND.

WE HAD A NICE LONG LETTER FROM MR. JAMES LACINA AND THE FELLOWS WORKING WITH HIM OUT ILLINOIS WAY AND THEY HAVE SOME MIGHTY GOOD IDEAS I WILL PASS ON TO YOU.

ONE HINT IS WHEN YOU ARE USING BANDSAW TO CUT SPAR CAPS IS TO HAVE A GOOD LEVEL SURFACE THE FULL LENGTH OF BAR AND DONT LET IT GET TOO HOT. ONE TRICK IS TO CUT ABOUT HALF WAY THROUGH LENGTH OF BAR & TURN AROUND AND CUT FROM OTHER END. THIS HELPS ON COOLING AND THERE IS LITTLE CHANCE OF STRAYING OUT OF LINE OR HAVING BAR TO COCK SIDWAYS. ANOTHER COOLANT COULD BE DRY ICE.

THESE FELLOWS INCLUDING MR. LACINA USED THE OLD FILE AND SANDING METHOD. A LOT OF ELBOW GREASE, I BET.

IF A HIGH SPEED CUTTER OF ANY TYPE IS USED, BE SURE TO SECURE CAPS GOOD BEFORE THIS IS ATTEMPTED. I BELIEVE THIS WOULD BE A GOOD IDEA REGARDLESS OF WHAT METHOD OF FINISHING IS USED.

ON ASSEMBLY OF SPAR MAKE SURE YOU HAVE A PERFECTLY LEVEL AND STABLE SURFACE TO START WITH AS THIS WILL ELIMINATE A LOT OF PROBLEMS. A GOOD WORKING HEIGHT IS 30" to 40".

MATERIAL USED BY MR. LACINA TO MAKE FORMS WAS BENELEX 70 MADE BY MASONITE CORP. THIS IS TOUGHER AND DENSER THAN MASONITE. USE THE 1" THICK, THIS SEEMS TO BE THE BEST.

THANKS A MILLION, JAMES, I WISH I COULD PUT ALL THE DETAILS AND DIAGRAMS IN.

MR. J. A. THIMSEN - RT. 5 BOX 176 T - RICHMOND 31, VIRGINIA IS INTERESTED IN DOING SMALL MACHINE WORK FOR THE PL-1. HE ALSO STATES THAT A WOOD PLANE CAN BE USED TO PLANE DOWN THE EXCESS ALUMINUM AFTER SPLICING SPAR CAPS. CUTTING SURFACE OF BLADE SHOULD BE ABOUT 80° TO 85° TO SURFACE OF BAR BEING PLANED.

LOTS OF LUCK ON YOUR OWN DESIGN, J. A.

MR. MERRILL ROTH OF PORTLAND, OREGON HAS STATED THAT HE IS GOING TO MILL OUT FOUR SETS OF SPAR CAPS ABOUT THE END OF THIS MONTH & THEY WILL BE IN THE NEIGHBORHOOD OF \$180.00 FOR THE FOUR CAPS, SPLICE BARS AND MATERIAL. EXACT PRICE WILL BE AVAILABLE AFTER MACHINING IS DONE. SO LET MERRILL KNOW IF YOU MIGHT BE INTERESTED.

ALSO I HAVE ONE MORE SET OF LANDING ATTACH PLATES LEFT THAT SHOWS SOME OF MR. ROTH'S WORKMANSHIP. THEY ARE MACHINED AND DRILLED AT \$8.00 FOR THE SET OF FOUR.

MR. ROTH'S ADDRESS IS: MR. MERRILL ROTH - % ROTH MFG. CO. - 811 NORTHWEST 23RD. AVE., PORTLAND 10, OREGON.

~~XXXXXXXXXXXXXXXXXXXX~~ MR. DICK POSTON HAS A RUN OUT 012351C THAT HE WILL SELL AS IS OR WILL BENCH MAJOR IF REQUESTED OR DESIRED.

MR. BILL GOFF - 3235 DARROW RD. - STOW, OHIO - 44224 HAS SEVERAL ITEMS YOU MIGHT BE ABLE TO USE. THEY ARE: VENEER THROTTLES, \$5.00 EACH - INSTRUMENT CLUSTER FROM CESSNA INCLUDES 2 FUEL GAUGES - OIL PRESSURE AND OIL TEMP., \$ 14.00 EACH. OTHER INSTRUMENT CLUSTER INCLUDE 2 FUEL GAUGES, OIL PRESSURE AND OIL TEMP., CYL. HEAD TEMP. & AMP. METER FOR \$16.50. ALSO GOODYEAR 6.00 x 6 WHEELS WITH DISC. BRAKES FOR \$60.00 EACH.

METAL AND WOOD BRAKES FOR PL-1 BUILDERS

(THESE SKETCHES SERVE ONLY AS A FORMULATION OF IDEAS
AND DO NOT CONSTITUTE WORKING DRAWINGS: OR DO THEY
NECESSARILY CONVEY SIZE RELATIONSHIP OF PARTS.)

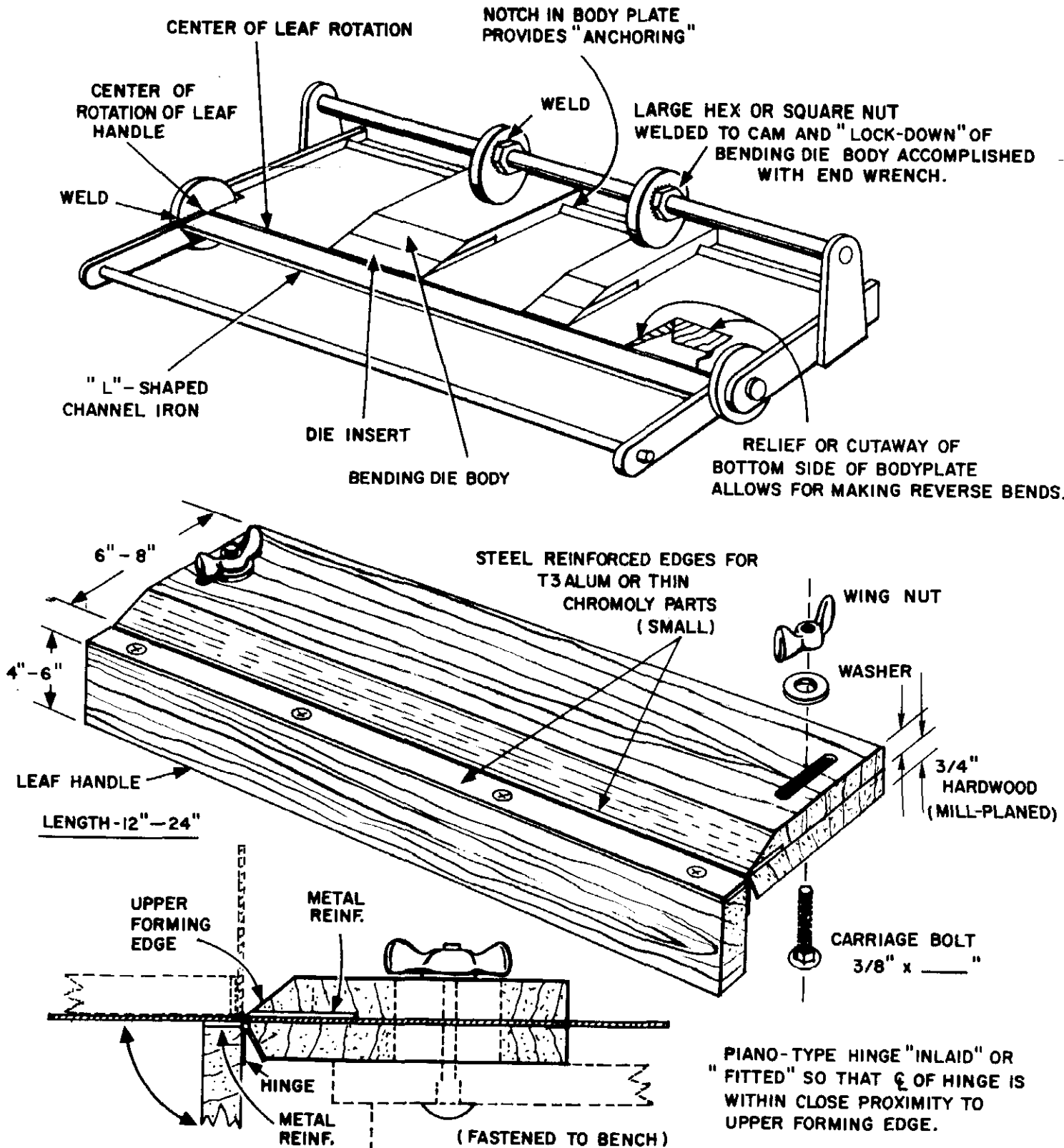

PIANO-TYPE HINGE "INLAID" OR "FITTED" SO THAT ϵ OF HINGE IS WITHIN CLOSE PROXIMITY TO UPPER FORMING EDGE.